



PROMEBA
EMERGENCY & RESCUE



USER GUIDE

MANUAL STRETCHER SERIES PC-900

Review 2022/01



INDEX

01	INTRODUCTION.....	05
01.1	Using this manual.....	05
01.2	Legend of symbols.....	05
01.3	Servicing request.....	05
01.4	Demolition.....	06
01.5	Labelling.....	06
01.6	Contraindications and adverse effects.....	06
01.7	Physical requirements of the operators.....	06
01.8	Intended purpose.....	07
01.9	General warnings.....	07
01.10	Specific warnings.....	09
01.11	Residual risk.....	11
01.12	Reference standards.....	11
01.13	Life span.....	11
02	PRODUCT DESCRIPTION.....	12
02.1	Main components.....	12
02.2	Technical data sheet.....	13
02.3	Features.....	14
03	OPERATION.....	15
03.1	Transport and storage.....	15
03.2	Preparation.....	15
03.3	Functioning.....	16
03.4	Troubleshooting.....	20
04	GENERAL MAINTENANCE.....	21
05	SPARE PARTS AND ACCESSORIES.....	22
05.1	Spare parts.....	22
05.2	Accessories.....	23
06	TRAINING REGISTER.....	24
07	MAINTENANCE REGISTER.....	25
08	LEGAL NOTICES.....	26
09	PRODUCT WARRANTY.....	27



01 INTRODUCTION













01.1 Using of manual

The manual provides using and maintenance instructions of the product as well as technical aspects, functioning, spare parts and safety.

It is recommended before the operation of the product to read carefully this manual in order to avoid damages caused by a misuse.

Do not lose this document. It should be accessible to any doubt that could appear by medical personnel. Remember that a good use and maintenance are necessary for the proper operation of the product.

01.2 Legend of Symbols

SYMBOL	EXPLANATION / DESCRIPTION
	MANUFACTURER symbol. This symbol is accompanied by the name and address of the manufacturer, adjacent to the symbol (PRODUCTOS METÁLICOS DEL BAGÉS S.L., Ctra. C-16 Km 59.5, 08650 Sallent (Barcelona)).
	Indicates the manufacturer's reference number to identify the medical device. PROMEBA, S.L. uses this symbol to set each internal reference for each configuration and business variant.
	Indicates the manufacturer's serial number to identify a specific medical device.
	Indicates the manufacturing date. The symbol must be accompanied by a manufacturing date (yyyy-mm), adjacent to the symbol.
	It is placed to inform that the product is a "Medical Device".
	CE symbol without the intervention of a Notified Organism, as a Medical Device classified as Class I according to the EU Regulation 2017/745 on Medical Devices.
	Symbol for the Unique Device Identifier.
	Symbol "See instructions for use or operating instructions".
	Symbol "caution". This symbol is placed to warn of the need for the user to refer to important precautionary information in the operating instructions, such as warnings and cautions not otherwise found on the label.
	Symbol "Caution". For a general warning.
	Warning, crushing of hands
	Indicates the temperature limits. The upper and lower temperature limits should be indicated adjacent to the horizontal lines.

01.3 Servicing request

For information of the correct interpretation of the instruction manual, the use, maintenance, installation and restoration of the product, please contact Promeba customer service: T. 93 837 12 00, email promeba@promeba.com or write to PROMEBA, S.L. - Ctra C-16 Km 59.5 · 08650 Sallent (Barcelona) · SPAIN.

01 INTRODUCTION

01.4 Demolition

When the devices are no longer suitable for use, if they have not been contaminated by any particular agent, they can be disposed of as normal solid waste, otherwise, follow the current demolition regulations.

01.5 Labelling

Each product incorporates an identification label, placed on the device itself and/or on the box. It must never be removed or covered. This label includes the serial number and the product code. Please keep these numbers so you can inform the dealer if necessary.

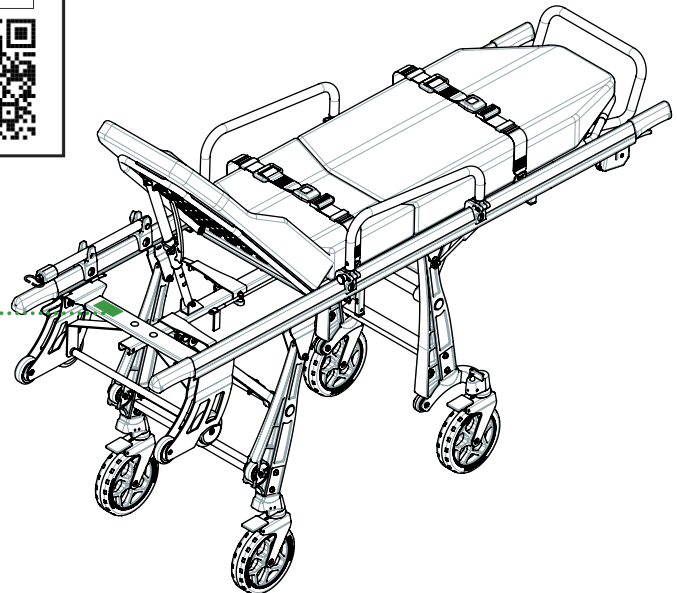

01.6 Contraindications and adverse effects

The use of this device, if used as described in this manual, does not present any contraindications or collateral effects.

01.7 Physical requirements of the operators

Promebea stretcher is destined to professional use only. The operators must be trained in efficient, effective and safe patient transport and must have the following minimum requirements:

- Physical capacity for operating the device
- Be able to seize the device firmly with both hands
- Have strong back, arms and legs for lifting, pushing and pulling the stretcher
- Have a good muscular coordination

It is recommended the employment of two operators equipped with strength, balance, coordination and common sense. Patient loading procedures for extremely heavy patients, operations in rough terrain and in particular situations more operators may be needed.



The capacities of the various operators must be considered before determining his role in the employment of the stretcher.

01 INTRODUCTION

01.8 Intended purpose

The product MANUAL STRETCHER SERIE 900 is indicated to load and transport with the less effort possible any type of patient in a cot or neonatal incubator in hospital and pre-hospital environments, including the transport with ambulances.

01.9 General warnings

1. The product must be used by trained personnel only, having attended specific training for this device and not for similar products.
2. At least every 6 months, is important to verify if updated User Manuals are available or there is any change involving your product. This information is freely available on the website <http://promeba.com/>
3. Training routines must be registered on a special register in which the names of those trained, of the trainers, date and place are indicated. This register, which will certify the eligibility of the operators to use the Promeba, S.L. device, has to be kept for a period of 10 years after the disposal of the device itself. This register will be made available to the competent authorities and/or manufacturer if requested.
4. Promeba, S.L. is always at your disposal to plan trainings on products.
5. Before carrying out any kind of operation on the appliance (training, installation, use), the operator must carefully read the enclosed instructions, paying particular attention to the correct safety precautions and to the procedures to be followed for installation and for correct use.
6. If the instructions belong to another device and not the device received, inform the manufacturer immediately and avoid use of the device.
7. In the case of any doubts as to the correct interpretation of the instructions, please contact Promeba, S.L. for any necessary clarifications.
8. Do not allow untrained persons to help during the use of the device, because they could cause damage to the patient or to themselves.
9. Regularly check the appliance and carry out the prescribed maintenance.
10. Before each use of device the perfect operating state of the device must be checked as specified in the instruction manual. If any damage or abnormalities which could in any way influence the correct functioning and the safety of the device, of the patient and/or of the user are detected, the device must be immediately removed from service and the manufacturer must be contacted.
11. If any failure or incorrect functioning of the device is detected, it must be immediately substituted with a similar item so that the rescue procedures are guaranteed without any interruption.
12. Use of the device in anyway other than described in this manual is forbidden.
13. Do not alter or modify in any way the appliance; any such interference could cause malfunctions and injury to the patient and/or rescuer.
14. The appliance must not in any way be tampered with (modification, adjustment, addition, replacement). In such cases all responsibility will be denied for any malfunctions or injuries caused by the appliance itself; moreover CE certification and product warranty will be considered void.
15. Those who modify or have modified, prepare or have prepared medical appliances in such a way that they no longer serve the purpose for which they were intended, or no longer supply the intended service, must satisfy the valid conditions for the introduction onto the market.

01 INTRODUCTION

16. Handle with care.
17. Ensure that all the necessary precautions are taken in order to avoid the hazards that can arise as the result of contact with blood or body fluids.
18. Register and store with these instructions: lot number, place and date of purchase, first date of use, date of checks, name of users, any comments.
19. When the device is being used, the assistance of qualified staff must be guaranteed.
20. Do not store the device underneath any heavy objects which could cause structural damage.
21. Store in a cool, dry, dark place and do not expose to direct sun.
22. Store and transport device in its original packaging.
23. The device must not be exposed or come into contact with any source of combustion or inflammable agents.
24. Position and adjust the device taking care not to cause any obstruction to rescuers and or any other rescue equipment.
25. Attention: laboratory testing, post production tests and instruction manuals cannot always consider every possible scenario for use. This means that in some cases the performance of the product could be notable different from results to date obtained. Instructions are continually being updated and are under tight surveillance of fully qualified staffs with adequate technical formation.
26. Both public and private operators are obliged to inform the manufacturer of any measures that should be adopted to guarantee the safety and the health of the patients and the users of any medical device.
27. As a distributor or end users of products manufactured and/or marketed by Promeba, S.L., you are strictly required to have a basic knowledge of any legal requirements existing in the goods final destination country applying to the devices contained in this supply (including laws and norms regarding technical specifications and/or safety requirements) and therefore you are also strictly required to have the necessary knowledge to guarantee all aspects regarding the total conformity of the products to the regulations in the relevant territory.
28. Promptly notify PROMEBA regarding any revisions to be made by manufacturer in order to guarantee the conformity of the product to the territory's legal specifications (including those resulting from rules and/or norms of other nature).
29. Act with all due care and diligence, and contribute to ensure conformity to general safety requirements of all devices marketed in the territory, by providing final users with all necessary information for carrying out periodical checks on their devices, as specified in the relevant user manual.
30. Actively contribute to product safety checks on products sold, by communicating any relevant risk analysis information both to the manufacturer and to any competent authorities so that the necessary actions can be promptly taken.
31. Be aware that in the event of any failure to conform to the above mentioned requirements you will be deemed fully responsible for all damages that might occur. Therefore we expressly disclaim any responsibility and/or liability for your non-compliance with the present "Regulatory provisions".

01 INTRODUCTION

01.10 Specific warnings

1. Establish a maintenance program and periodic testing, identifying a reference employee. The person to whom the ordinary maintenance of the device is entrusted must ensure the basic requirements foreseen by the manufacturer in the user's manual.
2. Use only accessories/spare parts that are original or approved by Promeba, S.L. when carrying out any operation, to avoid causing any alteration or modification to the device, otherwise we assume no responsibility for the proper functioning or damage resulting from device to the patient or the operator and warranty will be considered void.
3. Always respect the maximum capacity of the device, as indicated in this user's manual. Maximum load capacity means the total weight distributed according to the human anatomy. In determining the load of the total weight on the product, the operator must consider the weight of the patient, the equipment and the accessories. Moreover, the operator must consider that the overall dimensions of the patient do not reduce the functionality of the device.
4. Ride with extreme care and avoiding potholes as much as possible when the stretcher is loaded with a weight greater than 180kg.
5. Never leave the patient unassisted on the device, because he may be injured.
6. Do not use bleach to disinfect the product. Use a hydroalcoholic based disinfectant and wash with water.
7. The device and all its components, after washing, should be allowed to dry completely before storing.
8. Lubrication must be carried out after cleaning and complete drying.
9. Avoid contact with sharp objects.
10. Do not use the device if it is pierced, torn or frayed.
11. Make sure, before lifting, that the operators have a firm grip on the device.
12. Avoid pulling the device on rough surfaces.
13. The device is a stretcher for patients transport and cannot be used as a stationing device.
14. First practice with an empty stretcher in order to get used to the way in which the stretcher maneuvers.
15. For the use of the device, one operator in suitable physical conditions is needed, with strength, balance, coordination, and common sense and must be trained on the correct functioning of the device Promeba, S.L. stretcher.
16. For particularly heavy patient loading and for rescue operations on steep terrain or in unusual circumstances, the presence of more operators is recommended (not just one as required under standard conditions).
17. Before each use check the integrity of the belts and their hooks, as specified in the user's manual. In case of malfunction or damage that may compromise the function and safety of the device, patient or operator, it is necessary to replace the belts.
18. Make sure the belts are properly fastened to the frame of the stretcher.
19. Always immobilize the patient, using the belts; lack of immobilization may cause serious damage.
20. Make sure the mattress is properly secured/anchored to the stretcher's board.

01 INTRODUCTION

21. Use adjustable stretcher covers on medical devices with board. Make sure it does not interfere with the footrest and does not prevent the operator from manipulating the handrails.
22. Do not operate in case the weight has not been distributed correctly.
23. The handrails may be damaged due to improper use. Keep the handrails always raised during patient transport.
24. Always grasp the structure or the telescopic handles to lift and carry the stretcher and not the handrails.
25. Avoid extreme force during the loading procedure of the stretcher on the ambulance. Too much force may have negative effects on the functioning of the trolley.
26. Keep the stretcher firmly if the patient is sitting.
27. Use the stretcher only as described in this user's manual.
28. Do not alter or modify the stretcher arbitrarily to make it fit into the ambulance: the modification may cause unforeseeable functioning and damages to the patient and operators. In any case the warranty will be lost.
29. Pay a lot of attention to possible obstacles (water, ice, debris, etc.) on the route of the stretcher, because they could cause loss of balance for the operator and compromise the proper functioning of the device. If you cannot set the path free from obstacles, choose an alternative path.
30. Condensation, water, ice and accumulations of dust can affect the correct operation of the device, making it unpredictable and causing a sudden alteration of the weight that operators have to carry.

01.11 Residual risks

The residual risks listed below have been identified only with reference to the intended use of the device:

1. Use by untrained personnel may result in injury to patient, operator, or third parties.
2. Inappropriate disinfection procedures can create a risk of cross infection.
3. If the device is not locked in the fixation system or is not positioned correctly, it could result in sudden and dangerous movements, which could cause injury to the patient and the operators. Always make sure that the locking system is properly anchored.
4. Failure to comply with the warnings for operators can create risks.
5. Failure to read and understand the product instructions can result in injury to the patient and operators.
6. Partial opening of the legs may result in the device falling to the ground. Make sure that the legs are properly locked before any handling and that the pistons are fully extended and stable.

01.12 Reference standards

REFERENCE	TITLE OF DOCUMENT
UNI EN ISO 1865-1	Patient handling equipment used in road ambulances. Part 1. General stretcher systems and patient handling equipment
UNI EN 1789	Medical vehicles and their equipment. Road ambulances



As a distributor or end user of the products manufactured and/or distributed by Promeba, S.L., you are strictly obliged to know the legal provisions in force in the country of destination of the goods, applicable to the devices to be supplied (including the regulations relating to technical specifications and/or safety requirements) and, therefore, understand the necessary requirements to ensure compliance of the products themselves with all the legal requirements of the territory.

01.13 Life span

If used as described in the following instructions, this device has a useful life of 10 years from the date of purchase.

This useful life can be extended with annual reviews carried out by the manufacturer, which uses specialized and authorized internal and external technicians.

In case these annual checks are not carried out, the device must be disposed of according to the information in paragraph 01.4 and the manufacturer must be notified.

Only the manufacturer or an authorized center can extend the life of the device, if it meets the safety requirements.

Promeba, S.L. will not accept any responsibility for malfunction or damage caused by the use of devices that have not been checked by the manufacturer or authorized center, or that have exceeded the maximum allowed useful life.

02 PRODUCT DESCRIPTION

02.1 Main components

N°	DESCRIPTION OF COMPONENTS	N°	DESCRIPTION OF COMPONENTS
1	Guide	8	Rear legs
2	Profiles	9	Return piston rear legs
3	Board with Trendelenburg function (Fowler optional)	10	Front legs lever
4	Handrails	11	Rear legs lever
5	Backrest lever	12	Intermediate position lever
6	Attack wheels	13	Ergoload system (optional)
7	Front legs	14	Quick Lock system (optional)

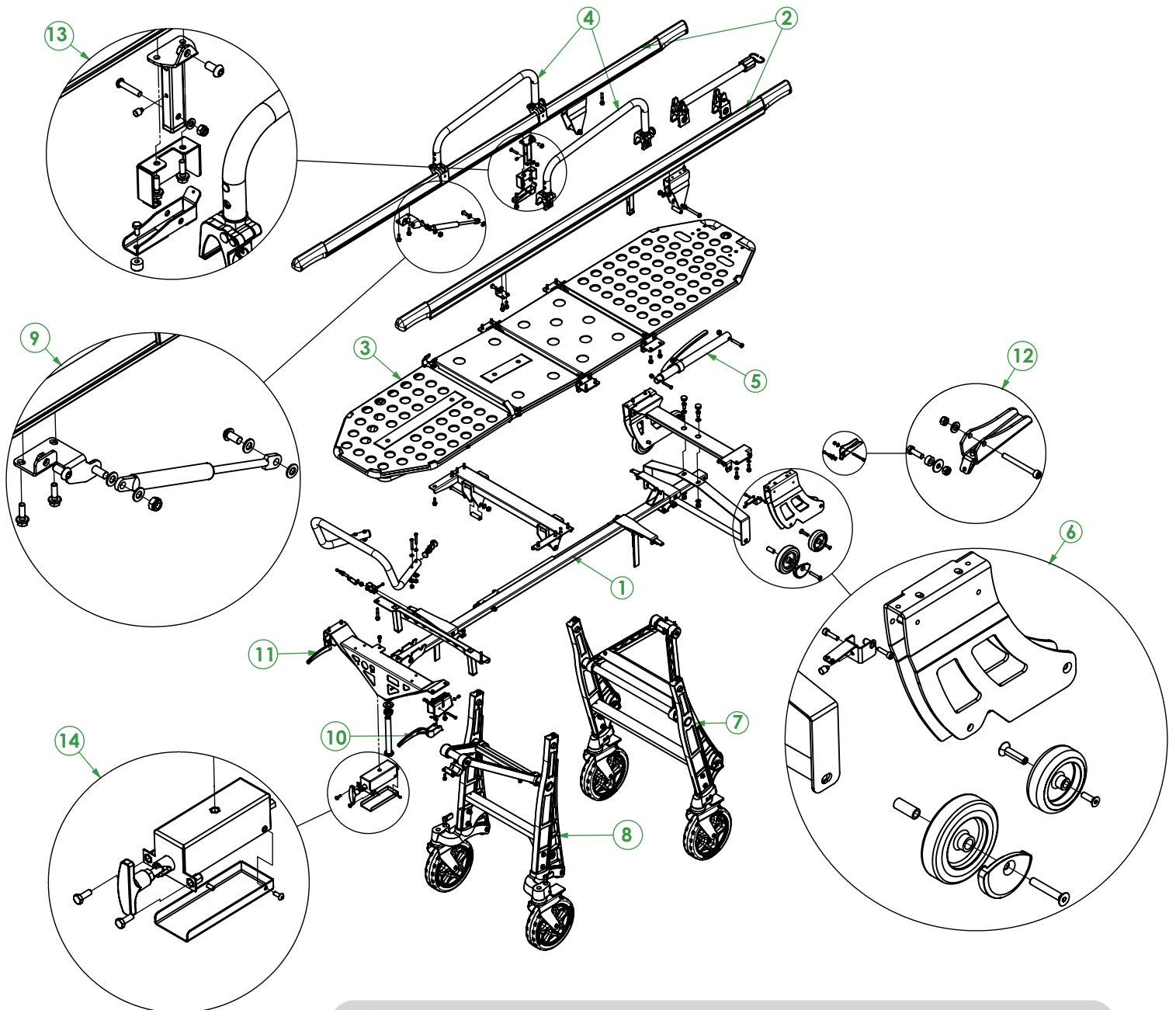

The drawing is indicative. Depending on the model obtained, it may present design variations according to its performance.

02 PRODUCT DESCRIPTION

02.2 Technical data sheet

MODELS	Inverted stretcher (PC-901, PC-902)	Standard stretcher (PC-921, PC-922)	Stretcher Performance (PC-911, PC912, PC913)	Stretcher with Fowler (PC-951, PC-952)	Incubator stretcher (PC-904)	Funeral stretcher (PC-905)	Stretcher trolley (PC-916, PC-917, PC-918)
Length (A)	1940 ±5 mm	1940 ±5 mm	1940 ±5 mm	1940 ±5 mm	1930 ±5 mm	1925 ±5 mm	1940 ±5 mm
Width (B)	585 ±5 mm	585 ±5 mm	585 ±5 mm	585 ±5 mm	605 ±5 mm	570 ±5 mm	585 ±5 mm
Height (C)	940/1040 ±5 mm	940/1040 ±5 mm	940/1040/ 1080 ±5 mm	940/1040 ±5 mm	860 ±5 mm	960 ±5 mm	1030/1130/ 1160 ±5 mm
Loading height (D)	560/660 ±5 mm	560/660 ±5 mm	560/660/740 ±5 mm	560/660 ±5 mm	560 ±5 mm	560 ±5 mm	560/660/740 ±5 mm
Weight	42/43 kg	42,5/43,5 kg	43/44/46 kg	43,5/44,5 kg	54 kg	45 kg	54/55/57 kg
Max. load	250kg	250kg	250kg	250kg	250kg	250kg	250kg
Wheels	4xØ200 mm	4xØ200 mm	4xØ200 mm	4xØ200 mm	4xØ200 mm	4xØ200 mm	4xØ200 mm
Backrest inclination	75°	75°	75°	75°	NO	NO	75°
Fowler	NO	NO	NO	SI	NO	NO	NO
Trendelenburg	17°	17°	17°	17°	NO	NO	17°
Recommended operators	2	2	2	2	2	2	2
Needed operators	1	1	1	1	1	1	1
Operation temperature	-20 /+40 °C	-20 /+40 °C	-20 /+40 °C	-20 /+40 °C	-20 /+40 °C	-20 /+40 °C	-20 /+40 °C

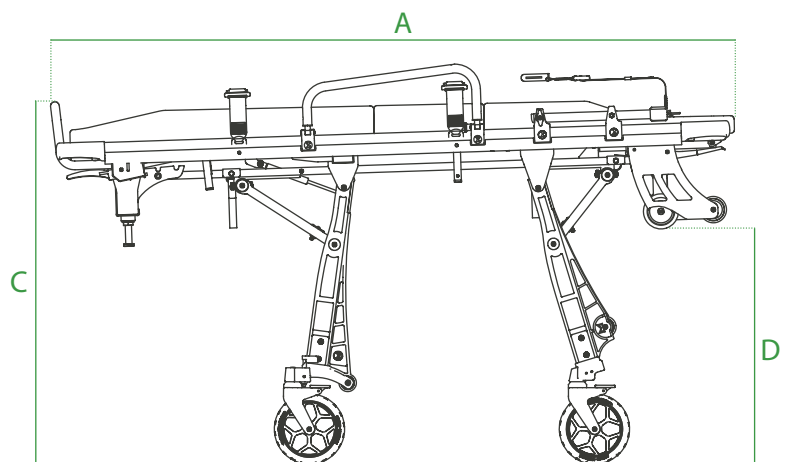
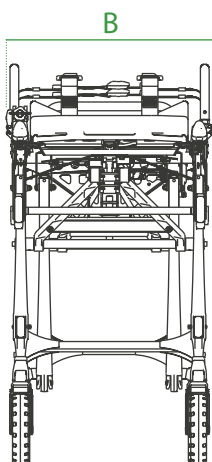

02 PRODUCT DESCRIPTION

02.3 Features

MODELS	Inverted stretcher (PC-901, PC-902)	Standard stretcher (PC-921, PC-922)	Stretcher Performance (PC-911, PC912, PC913)	Stretcher with Fowler (PC-951, PC-952)	Incubator stretcher (PC-904)	Funeral stretcher (PC-905)	Stretcher trolley (PC-916, PC-917, PC-918)
Aluminum construction for great strength and very light weight	X	X	X	X	X	X	X
Folding handrails to facilitate patient transfer, with the possibility of incorporating a kit for bariatric patients	X	X	X	X			X
12 positions to facilitate patient loading	X	X	X	X	X	X	X
Aluminum bed tray with built-in Fowler function				X			
Removable bed tray from the trolley to be able to load patients in environments where the stretcher cannot reach						X	X
Anatomic heat-welded mattress, easy to clean and prevents the entry of fluids	X	X	X	X			X
4 lockable swivel castors			X	X			X
Non-locking front wheels and lockable rear wheels	X					X	
Locked front wheels and lockable rear wheels		X			X		
Belt anchoring system that allows easy change for cleaning	X	X	X	X		X	X
Reinforced footrest that allows to drive and load the stretcher with the hands on it to improve the ergonomics	X	X	X	X	X	X	X
Handles with reinforced material to open doors without breaking	X	X	X	X	X	X	X
Rubber seal to avoid scratches and keep the stretcher looking new for longer	X	X	X	X	X	X	X
4 attack wheels to improve load and reduce wear	X	X	X	X	X	X	X
Reclining backrest by manual operation	X	X	X	X			X
Telescopic handles for better maneuverability	X	X	X	X	X	X	X
Folding and adjustable IV pole	X	X	X	X	X		X
Stainless flat tray to anchor incubator					X		
Incorporates Quick Lock system to lock the front wheels from the back of the stretcher			X	X			X
It incorporates the ErgoLoad system that allows maneuvering and loading the stretcher with a much more ergonomic position			X	X			X

03 OPERATION

03.1 Transport and storage

Before transporting the appliance, make sure that it is correctly packaged.

During transport always fix the load. If piling up is necessary always follow the scheme shown on figure 1.

Transport the leveled load and following all precepts and rules for the transport of loads, ensuring also that there are no risks of shocks, bumps or falls during the transport itself.

To unpack the device place the box on a flat, stable surface and carefully open the seal. Remove the device from the inside of the box following the scheme shown on figure 2.

Keep the original packaging for use in case of any further transport and for storage.

Damage to the appliance caused during transport and handling is not covered by the guarantee. Repairs or replacement of the damaged parts are the responsibility of the client.

The device must be stored in a dry, cool area away from direct sunlight. It must not be placed in contact with any substances or chemical agents which could cause damage and reduce safety characteristics.

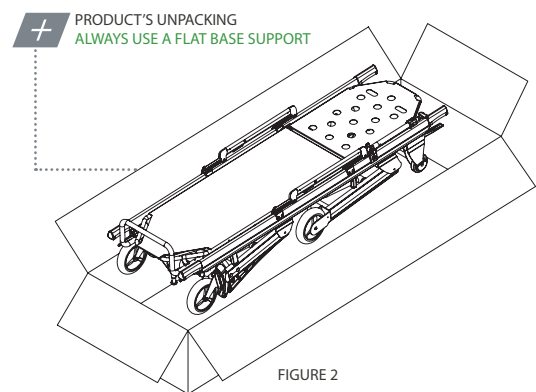
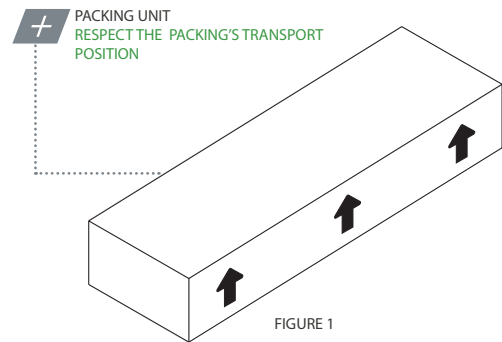

03.2 Preparation

On receipt of the product:

- Remove the packaging and display the material so that all components are visible.
- Check that all the components/pieces on the accompanying list are present.

The appliance must be checked before every use so as to reveal any working abnormalities and/or damage caused by transport and/or storage. In particular, check:

- General functionality of the device
- Cleanliness of the device (remember that the failure of cleaning may cause the risk of cross infections)
- Absence of cuts, holes, tears on the structure, including the straps
- Correct fixation of all nuts, bolts and screws
- Correct fixation of belts
- Correct fastening of belts
- State the moving parts, wheels and belts
- Integrity of components
- Lubrication of moving parts
- When taking out for the first time the stretcher from its box, check that legs bend and lock properly
- Backrest and Trendelenburg (and Fowler if it has) work properly
- Handrails are raised and lowered properly
- State of use of wheels and breaking system
- Functioning of springs
- The stretcher can easily get in the ambulance
- The emergency vehicle is equipped with a fastening system suitable for the stretcher
- Welding are intact, no cracks or breaks
- No piping or metal sheet present bends or cracks
- The backrest has no structural damages or fissures

If the above conditions are met, the device may be considered ready for use; otherwise you must immediately remove the device from service and contact the manufacturer.

03 OPERATION

03.2.1 REQUIREMENTS OF THE EMERGENCY VEHICLE

The Promeba stretcher has been designed to enter and exit the patient compartment of an ambulance. The vehicle must have a levelled loading platform, wide and long enough for the Promeba stretcher and without obstacles.

To configure the height of the platform you must take into account these two requirements:

- **Maximum loading height:** you can check the height of each stretcher model in the table of the section 02.2.
- **Minimum loading height:** when the attack wheels are placed on the platform and the front legs touch the platform, the front wheels must be at least 5 cm from the ground (see figure 3)



Failure to comply with these requirements can lead to a malfunction in the opening and closing of the legs.

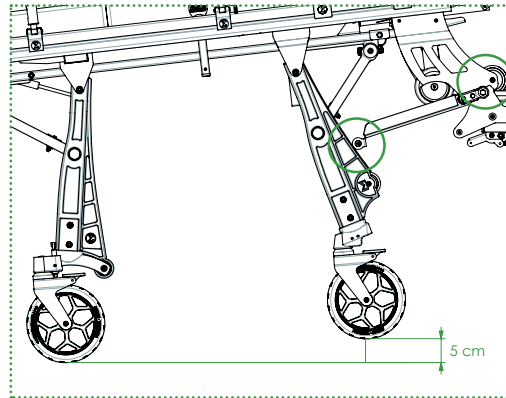

FIGURE 3

The measurement of the loading platform must be taken with the ambulance positioned on a uniform and perfectly horizontal surface and with two operators seated in the patient compartment (simulating a load of approximately 250 kg).

If the vehicle is equipped with pneumatic or hydraulic suspensions, the loading height adjustment must be carried out taking into account the worst conditions of use and/or the operating one provided by the vehicle builder. Problems during use and/or safety risks associated with such system, cannot be attributed to the manufacturer.

Try out the loading and unloading procedures with an empty stretcher before putting the stretcher into regular service.

03.2.2 LOADING THE PATIENT ON THE STRETCHER

Before transferring, lifting or transporting the patient, primary medical evaluations have to be performed. Once the diagnosis has been assured, it is preferred (if possible) to suggest the patient to collaborate actively during the transfer onto the stretcher, making sure the patient is fully aware of all risks.

Before loading the patient, move the stretcher as close as possible to him, if it is necessary for facilitating the operations, position the stretcher in the intermediate height (paragraph 03.3.5).

03.3 Functioning

03.3.1 STRETCHER CIRCULATION

When the stretcher is circulating, the following indications must **ALWAYS** be observed:

- Ride on flat ground, with extreme care and avoiding potholes
- Pay a lot of attention to possible obstacles (water, ice, debris, etc.) on the route of the stretcher. If you cannot set the path free from obstacles, choose an alternative route.
- The stretcher must be fully unfolded when driving.
- You must always drive with all four wheels in contact with the ground.
- A properly trained operator must always be in the control position.
- Always respect the maximum capacity of the device considering the total weight distributed according to the human anatomy and also taking into account the weight of the equipment and accessories. Do not circulate if the weight has not been distributed correctly.



In the event of any failure to conform to the above mentioned requirements you will be deemed fully responsible for all damages that might occur. In such cases, Promeba, S.L. will deny all responsibility for any malfunctions or injuries caused by the appliance itself; moreover product warranty will be considered void.

03 OPERATION

03.3.1 LOWERING THE STRETCHER

Make sure the handrails are positioned upwards and locked; otherwise the stretcher may be damaged. Before lowering the stretcher, reach the place where to make the following operations.

Lower the stretcher without patient, as follows:

1. Grab telescopic handles of the stretcher at the rear end (feet)
2. Lift the rear part (feet) of the stretcher, until the attack wheels touch the ground
3. Holding firmly the stretcher, push both command handles (n° 13 and 14 paragraph 02.1) in order to close the legs
4. Lower the stretcher, carrying its weight, until it touches the ground.

Before loading the patient, while the stretcher is on the ground, make sure the underground is stable and horizontal; unstable and non-horizontal surfaces may affect the static balance of the stretcher. Brake the front wheels (optional) when the stretcher is on the ground and do not forget to unblock them before raising the stretcher.

03.3.2 LIFTING THE STRETCHER

Before lifting the stretcher fix the patient on the stretcher with the belts and make sure the underground is safe and stable.

The following procedure is recommended to lift the stretcher:

1. Two operators must be positioned to each edge of the stretcher. The capacities of the various operators must be considered before determining his role in the process (consider how many operators to employ according to the weight to lift and according to the capacities of each operator).
2. Make sure to grab the stretcher firmly at both ends.
3. Using an adequate lifting technique, lift the stretcher until the legs, front and rear, are open and completely blocked.

03.3.3 LOADING THE STRETCHER ONTO THE AMBULANCE

Make sure the ambulance's doors are blocked correctly in open position, in order to avoid any hindrances. Make sure the handrails are blocked in upward position, otherwise the stretcher may be damaged.

During the charging operation:

1. Place the stretcher towards the rear door opening of the ambulance.
 2. Push it onto the loading platform of the ambulance.
 3. Make sure that both attack wheels (n° 7 paragraph 02.1) are positioned on the loading platform (safety position) and operate the red lever (n° 13 paragraph 02.1) to unlock the front legs.
 4. Push the stretcher into the ambulance, keeping the red lever pushed so that the front legs fold up and close; avoid strong blows of the front legs against the load platform; the legs and related mechanisms could be damaged.
 5. Insert the stretcher into the ambulance until the rear legs touch the platform, then lift the stretcher slightly and operate the green handle (n° 14 paragraph 02.1) to unlock the rear legs and complete the stretcher loading procedure.
- * If you have a model with Ergoload system (see models with Ergoload in paragraph 02.3) do not operate the green lever in this step. Just keep loading the stretcher to the ambulance and the rear legs will automatically unlock.

6. Make sure the stretcher is securely attached to the ambulance fixture.

** It is recommended to use the original fixing systems Promeba, S.L. to ensure optimal stability in all directions. As long as other fixing systems are used, the safety and correct functionality of the device is not guaranteed.

03 OPERATION

03.3.4 UNLOADING THE STRETCHER FROM THE AMBULANCE

During the download operation:

1. Unlock the stretcher from its fixation system.
2. Hold the stretcher by the rear telescopic handles and gently pull it out of the ambulance.
3. Hold the stretcher until the rear legs open and lock automatically.
4. Before removing the attack wheels from the platform (safe position), make sure that the front and rear legs have been opened and locked correctly and that the ground is stable and safe.



ATTENTION: When setting the loading height, the vehicle is considered to be on levelled ground. If this condition is not met when unloading the stretcher, its operation could vary slightly from what was expected.

In this case, pay special attention that the front and rear legs are fully open and locked before removing the attack wheels from the platform.

3.3.5 INTERMEDIATE POSITIONS

The Promeba stretcher offers up to 12 different heights, making easier the transfer of a patient from the stretcher to a bed and back, optimizing the loading procedures with elder or handicapped people.

The following procedure is recommended to reach the intermediates positions:

1. Bring the stretcher to the place of operations and make sure the ground is stable and safe.
2. Two operators must be positioned to each edge of the stretcher
3. The operator positioned on the rear edge (feet) of the stretcher will lift it slightly and push the green handle (n° 14 paragraph 02.1) unlocking the rear legs.
4. Always supporting the stretcher load, lower it until the required position and let the lever go.
5. The operator positioned on the front edge (head) of the stretcher will lift it slightly and push the red handle (n° 15 paragraph 02.1) unlocking the front legs.
6. Always supporting the stretcher load, Flower it until the required position and let the lever go.

The following procedure is recommended to return the stretcher to the standard position:

1. Two operators should be positioned at each edge of the stretcher.
2. Make sure the ground is safe and stable.
2. Hold the stretcher firmly at both ends.
3. Using proper lifting technique, raise the stretcher. The front legs will open and lock automatically.
4. The operator at the front edge should push the front legs with their foot until they are fully open and locked.

03.3.6 ADJUST PATIENT BOARD

Always inform the patient in case the patient board has to be adjusted.

Adjusting the backrest

Follow these indications:

1. Support the backrest with one hand (to avoid unexpected movements) and push the lever (n° 5 paragraph 02.1) until the security mechanism is unblocked.
2. Always supporting the backrest with one hand, lower or lift the backrest until the required position and let the lever go (six positions, plus horizontal position, available).

03 OPERATION

Trendelenburg position

The Trendelenburg movement allows the lifting of the board in order to higher the legs of the patient (see Figure 4).

To put the board in Trendelenburg position:

1. Lift the board with one hand taking away the weight.
2. Select the required position by placing the rod onto one of the slots. There are three available positions, plus horizontal position

To put the board horizontal again:

1. Lift slightly the board
2. Release the rod from the slot and lower the board until the horizontal position is reached.

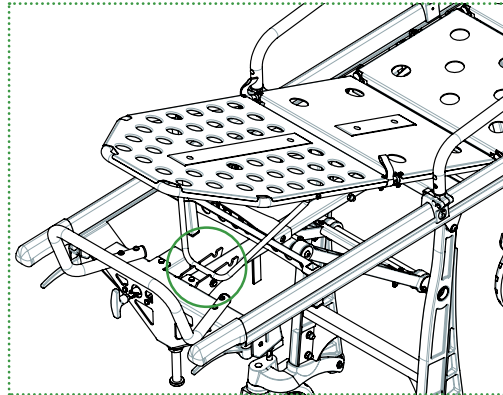

FIGURE 4

Fowler position

(see models with Fowler in paragraph 02.3)

The Trendelenburg/Fowler movement allows the lifting of the patient board into different positions, in order to higher the legs of the patient (see figure 5).

To put the board in Fowler position:

1. Support and lift the board with one hand taking away the weight.
2. Select the required position by placing the rod onto one of the slots (three positions, plus horizontal position, available).
3. Once on Trendelenburg position, pull the red straps placed on both sides of the board, at patient's knees height, to get the Fowler position.

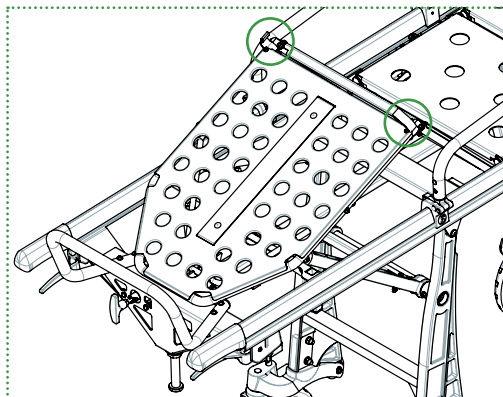

FIGURE 5

To put the board horizontal again:

1. Pull the straps down to return to Trendelenburg position.
2. Lift slightly the board
3. Release the rod from the slot and lower the board until the horizontal position is reached.

03.3.7 HANDRAILS

In order to avoid accidental functioning, the handrails are designed to be opened with two hands.

1. Use one hand to unlock the positioner (see figure 6)
2. With the other hand pull the handrail down until it rotates up to 180°.

To put the handrails back in upward position:

1. Rotate them until they are up and properly locked.

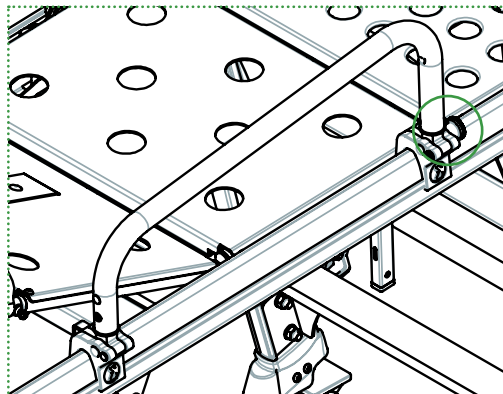

FIGURE 6

03 OPERATION

03.3.8 WHEELS

Brakes

The brakes can be inserted by pushing down the lever positioned on the upper part on all the wheels, (see figure 7). The brake system blocks the wheel, immobilizing the stretcher.

To unblock the brakes, pull the lever on the wheels.

Rear wheels

Rear wheels are always lockable.

To lock them rotate 90° the red lever, positioned on the top of it (see figure 8), and it will shift down slightly locking the wheel.

To unlock, rotate the lever it 90° on the opposite side.

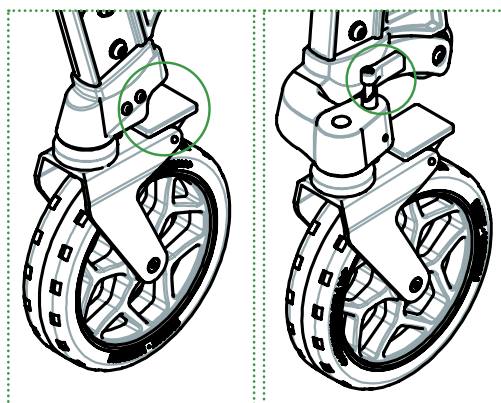

FIGURE 7

FIGURE 8

Front wheels (see models with front lockable wheels in paragraph 02.3)

Depending on the model, front wheels may be non-locking, locked or lockable.

In case of lockable front wheels, it is used the Quick lock system (n° 17 paragraph 02.1) placed on the rear part of the stretcher.

To lock the front wheels turn the handle 90° horizontally, move the stretcher first backwards and then forwards so that both wheels turn forward and lock

To unlock the front wheels turn the handle 90° vertically.

03.3.9 REMOVE THE STRETCHER FROM THE TROLLEY (See stretcher-trolley models in paragraph 02.3)

To remove the stretcher from the trolley, the use of two operators is recommended, one at each end of the trolley to be able to lift the stretcher correctly.

The recommended procedure is as follows:

1. Brake the trolley
2. Operate the center red lever on the back of the trolley.
3. Slide the stretcher about four 10 cm back.
4. Raise the stretcher from the trolley by holding it firmly at both ends. In the case of particularly heavy patients or adverse conditions, the use of additional operators is recommended.



ATTENTION: The stretcher can be placed in both directions on the trolley, but as long as it is within a circulating ambulance, it must be placed with the head in front and the feet behind.

03.4 Troubleshooting

PROBLEM	CAUSE	REMEDY
Pushing the stretcher against the loading platform, the legs do not fold away	The lever has not been actioned correctly or the metal cable under the stretcher does not transmit the commands	Fully operate the lever. If the problem is not solved contact the technical service
During patient transport it is difficult to move the stretcher	There may be an obstruction in the wheels: the brakes are still blocked or there is some external element blocking them.	Unlock the brakes or check that there is nothing blocking the wheels. Check the condition of the wheels.
Structural damage	Improper use or operators not adequately trained	Put the stretcher out of service immediately and contact the technical service

04 GENERAL MAINTENANCE

CLEANING

It is essential to keep the equipment clean to ensure a proper use and durability of the set. A thorough clean must be done periodically, especially in areas exposed to dirt that may be damaged such as gears or mobile elements. Do not use high-pressure cleaning systems, neither bleach to disinfect the product, they can damage it. Instead, use a hydroalcoholic based disinfectant, wash with water and let it dry naturally, do not use sources of direct heat to dry.

MAKE SURE TO KEEP AREAS FROM FIGURE 9 FREE OF WATER AND HUMIDITY. TAKE SPECIAL CARE NOT TO GET THEM WET WHILE WASHING THE SET.

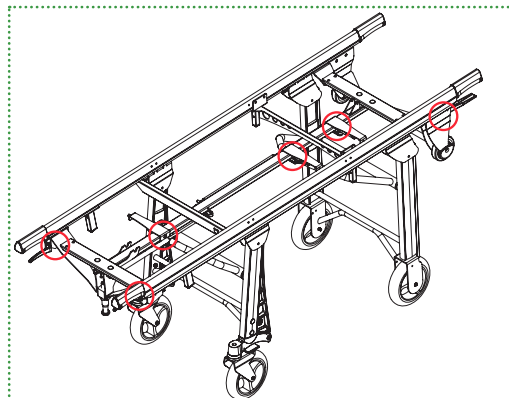

FIGURE 9

MOBILE ELEMENTS

Due to the intense and continuous use of mobile elements such as levers or commands, periodically examine its proper operating. Inspect the mechanical connections that may exist.

LUBRICATE

Generally, all moving parts must be lubricated. Our products leave the factory completely lubricated. However, it is possible that the elements lose lubrication with the passage of time and the use of the product, either due to loss of lubricant or dirt. Periodically clean and lubricate affected areas according to manufacturer's specifications. Check for loose, missing or worn parts. Periodically inspect all moving parts to ensure components are tight.

WEAR AREAS

Inspecting regularly on the system components for signs of wear is a preventive measure that can reduce breakdowns. Check possible lubricant leakages, grooves or bearing in poor condition.

MECHANICAL FIXING

We call mechanical fixing elements to the components used to fix the product as a whole, mainly screws and derivatives. To some terms of use, due to vibrations or impacts, certain elements may lose their tightening torque or fixing properties. Periodically review that there are no loose elements, especially on moving parts. Please note and always respect the recommended tightening torques.

REPLACEMENT OF COMPONENTS

In the event that certain mechanical parts need to be replaced by qualified service personnel, they should contact our sales department for more information on ordering spare parts and their installation.

MAINTENANCE SUMMARY	EVERY USE	WHEN NEEDED	EVERY MONTH	EVERY YEAR	EVERY 4 YEARS
DISINFECT	X				
CLEAN		X			
INSPECT		X	X		
LUBRICATE		X		X	
SPRINGS REPLACEMENT				X	
WHEELS REPLACEMENT					X

05 SPARE PARTS AND ACCESSORIES

05.1 Spare parts

To request a spare part, indicate:

- **Model** of stretcher that needs the replacement
- **Number and description** of the set in which the needed part is located (see table on the right)
- **Point out** the part in the drawing, or the area where it is located

Following these indications, our sales department will provide you with a detailed drawing of the set so that you can specify the reference of the required spare part.



The drawing is indicative. Depending on the model obtained, it may present design variations according to its performance.

N°	DESCRIPTION OF COMPONENTS
1	Guide
2	Profiles
3	Board
4	Handrails
5	Backrest lever
6	Attack wheels
7	Front legs
8	Rear legs
9	Return piston rear legs
10	Front legs lever
11	Rear legs lever
12	Intermediate position lever
13	Ergoload system (optional)
14	Quick Lock system (optional)
15	Main assembly

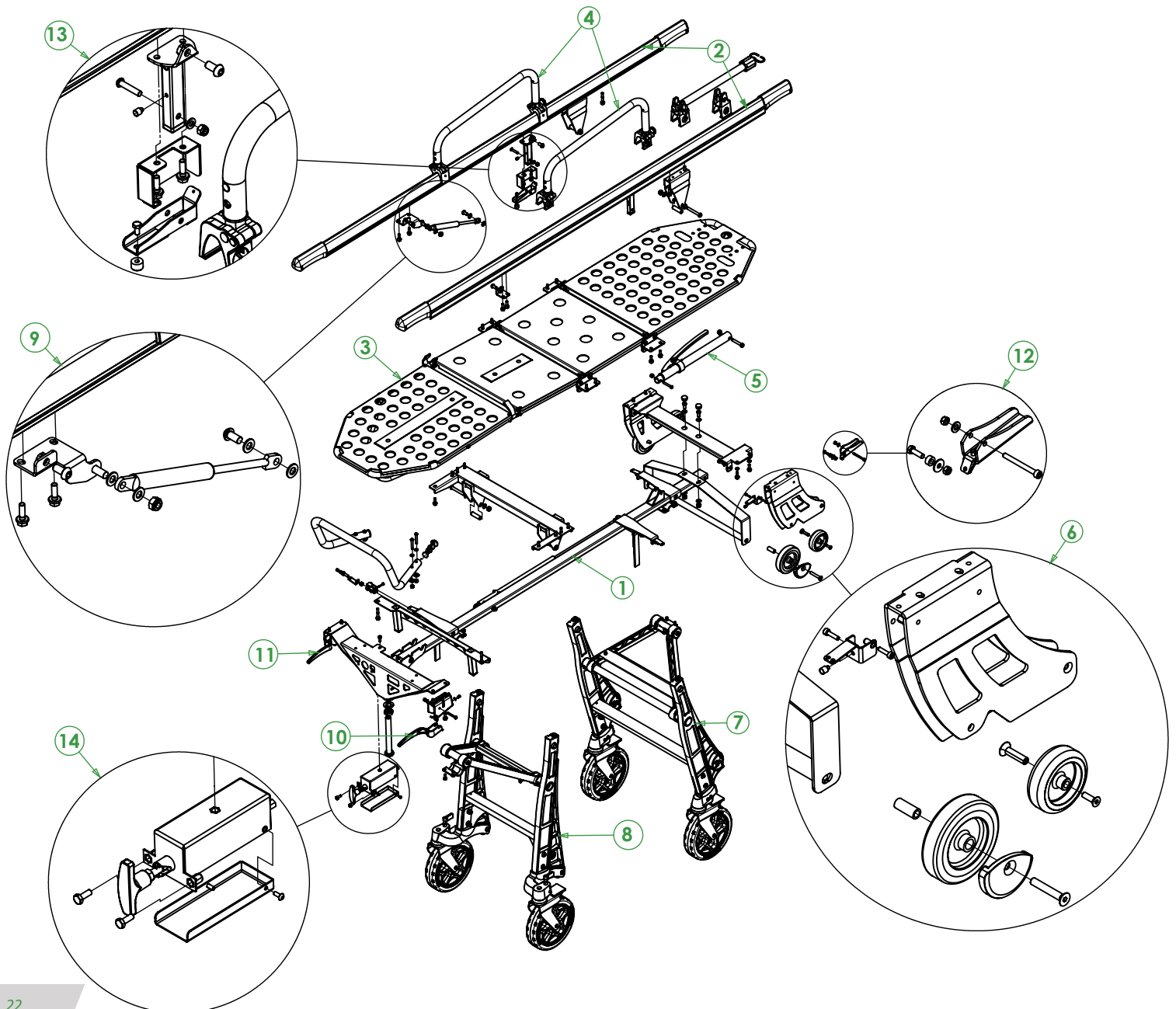

05 SPARE PARTS AND ACCESSORIES

05.1 Accessories

PA-632	MATTRESS
PA-750	MATTRESS FOR BOARD WITH FOWLER
PA-525	OXYGEN BOTTLE HOLDER
PA-620	IV POLE
PA-610	FOLDABLE INSTRUMENTAL TABLE
PA-760	BARIATRIC KIT
PS9020-00010	HOMOLOGATED SIMPLE BELT
PS3500-11110	HOMOLOGATED HARNESS BELT

08 LEGAL NOTICES

This document may contain technical inaccuracies or typographical errors.

Changes are periodically added to the information herein; these changes will be incorporated in new editions of the publication.

Promeba, S.L. reserves the right to make any modification or improvement in the products described in this publication if it is appropriate.

Promeba, S.L. may have patents or patent applications which address themes described in this document. The possession of this document does not entitle no license to these patents.

The information contained in this document does not affect or change the specifications or product specifications or warranties of Promeba, S.L.

No part of this document shall operate as express or implied license or compensation under the intellectual property rights of Promeba, S.L. or third party.

All the information contained in this document has been obtained in specific environments and it is presented as an illustration. The results obtained in other operating environments may vary.

Promeba, S.L. can use or distribute the information that the client provides in whatever way they see fit, without incurring any obligation with the client.

09 PRODUCT WARRANTY

Promeba, S.L. guarantees that its products have satisfactorily passed all established quality controls, both functional and material. The duration of the guarantee is 2 years from the date of purchase of the product.

This guarantee will be valid only when it is presented with the original invoice or proof of purchase (indicating the date of purchase, model and the name of the distributor) together with the defective product during the period covered by the guarantee. Promeba, S.L. reserves the right not to offer the free warranty service if the indicated documents are not presented or if the information they contain is incomplete or illegible.

1. This warranty will not apply if the model name or serial number of the product has been altered, erased, disappeared or becomes illegible.

2. This guarantee does not cover transportation costs or risks derived from the transportation of your product to and from Promeba, S.L.

3. This warranty does not cover any of the following:

a) Periodic maintenance and repair or replacement of parts derived from normal wear and tear.

b) Expendable material (components that are expected to need periodic replacement during the life of the product, such as non-rechargeable batteries, light bulbs, etc.).

c) Damages or defects derived from the improper use, operation or treatment of the product and not due to normal use of the product.

d) Damages derived from:

i. Misuse, including:

- Treatment that results in damages or physical, superficial or appearance changes of the product.

- Installation, use or storage of the product in a way that does not respect the instructions described by Promeba, S.L.

- Maintenance of the product in a way that does not respect the instructions of Promeba, S.L. for proper maintenance.

- Installation or use of the product in a way that does not respect the technical or safety regulations of the country where it is used or installed.

iii. Use of components not provided with the product or incorrect installation of accessory parts not previously tested.

iii. States or defects of the system in which the product is used or incorporated with the exception of other products Promeba, S.L. designed for use with the product.

iv. Use of the product with accessories, peripheral units and other products of a type, condition or standards not established by Promeba, S.L.

v. The manufacturer or distributor will be solely responsible for deciding whether to send the parts for repair, or to replace the product in its entirety. In no case will operators be sent to repair or replacement of the product.

Except in the cases mentioned above, Promeba, S.L. will make no warranties in relation to product, performance, accuracy, reliability, or fitness for logic purpose of the equipment or other type. If this exception is not legal or contemplated by current law, Promeba, S.L. will limit or exclude your warranties only to the extent permitted by applicable law.

The only obligation on the part of Promeba, S.L. in connection with this warranty is to repair or replace parts subject to the terms and conditions of this warranty.

Promeba, S.L. is not responsible for loss or damage to products, this warranty or others, including economic loss or non-assessable damage; the price paid for the product; loss of profits, income, information, usufruct or use of the product or associated products or indirect, accidental or critical loss or damage.

This clause refers to whether the loss or damage is due to deterioration or inoperability of the associated product due to defects or unavailability of Promeba, S.L., which has caused downtime, loss of user time or business interruption.

In cases where the law prohibits or limits these liability exclusions, Promeba, S.L. will exclude or limit his liability only to the extent permitted by applicable law. For example, there are countries that prohibit the exclusion or limitation of damages caused by negligence, reckless negligence, willful misconduct, fraud and similar actions. The responsibility of Promeba, S.L. In this guarantee will not exceed, in any case, the price paid for the product, but if the current law allows only limitations of greater responsibilities, these will apply.



Todos los derechos reservados. Reservado el derecho ha modificaciones sin previo aviso.
Promeba, S.L. no se considera responsabe de los daños causados por la falta o la inexactitud de la información aquí mencionada.

*All rights reserved. Variations can be done whitout notice.
Promeba, S.L. is to be considered not responsible for damages caused by the lack or the wrongness of the information here mentioned.*



PROMEBA, S.L.

Ctra C-16 Km 59.5 · 08650 Sallent (Barcelona) · SPAIN
T. 93 837 12 00
promeba@promeba.com · www.promeba.com