



USER GUIDE

**ELECTRIC STRETCHER SERIE PC-750 //
STRETCHER SUPPORT SERIE PB-720**

Review 202411



INDEX

01	INTRODUCTION	
01.1	Using this manual	04
01.2	Serving request	04
01.3	Demolition	04
01.4	Intended purpose	04
01.5	Contraindications and adverse effects	04
01.6	Legend of Symbols	05
01.7	Notices and warnings	06
01.8	Technical data sheet	08
02	INSTALLATION	
02.1	Transport and unpacking	14
02.2	Anchorage points	15
02.3	Connection to the mains power supply	16
02.4	Stretcher's launch	17
03	OPERATION	
03.1	Commands of the stretcher PC-750	19
03.2	Commands of the stretcher PC-751	20
03.3	Commands of the stretcher PC-755	21
03.4	Commands of the support PB-720	22
03.5	Commands of the support PB-725	23
03.6	Elements of the stretcher system PC-750 / PC-751 / PC-755	24
03.7	Elements of the support system PB-720 / PB-725	25
03.8	Loading and unloading operation	26
03.9	Control panel	27
03.10	Breakdowns	28
03.11	Troubleshooter	29
04	MOUNTING AND COMPONENTS	
04.1	Main exploded view of stretcher PC-750 / PC-751 / PC-755	31
04.2	Exploded view of lower assembly PC-750 / PC-751 / PC-755	32
04.3	Exploded view of third locking point PC-750 / PC-751 / PC-755	34
04.4	Exploded view of upper assembly PC-750	36
04.5	Exploded view of upper assembly PC-751	38
04.6	Exploded view of upper assembly PC-755	40
04.7	Exploded view of stretcher bed PC-750 / PC-751	42
04.8	Exploded view of batteries cabinet PC-750 / PC-751 / PC-755	44
04.9	Exploded view of handrail PC-750 / PC-751	46
04.10	Exploded view of telescopic frame PC-751	48
04.11	Exploded view of rear structure PC-750 / PC-751	51
04.12	Exploded view of charching system PC-750 / PC-751	52
04.13	Main exploded view of support PB-720 / PB-725	55
04.14	Exploded view of removable rail PB-720 / PB-725	56
04.15	Exploded view of x rail PB-720	58
04.16	Exploded view of platform PB-720	60
04.17	Exploded view of supplement PB-720	62
04.18	Exploded view of x rail PB-725	64
04.19	Exploded view of platform PB-725	66
04.20	Exploded view of screwed plate PB-720 / PB-725	68
04.21	Exploded view of third locking point PB-720 / PB-725	70
05	ELECTRICAL CIRCUIT DIAGRAM	
05.1	Printed circuit board	72
05.2	Electrical wiring diagram	73
06	GENERAL MAINTENANCE	75
07	LEGAL NOTICES	76
08	PRODUCT WARRANTY	77

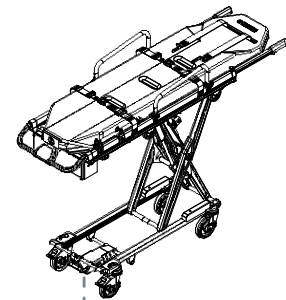

+ MODEL PC-750
STANDARD STRETCHER

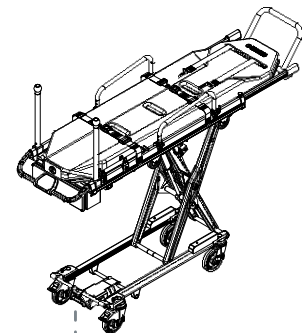

+ MODEL PC-751
ENGLAND STRETCHER

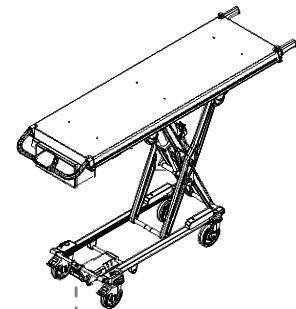

+ MODEL PC-755
INCUBATOR STRETCHER

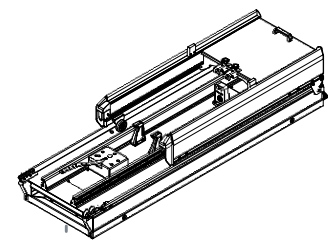

+ MODEL PB-720
SUPPORT WITH CABINET FOR
SCOOP STRETCHER

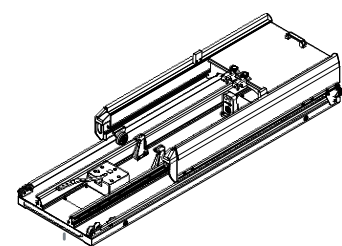

+ MODEL PB-725
SUPPORT WITHOUT CABINET
FOR SCOOP STRETCHER

01 INTRODUCTION

01.1 Using of manual

The manual provides using and maintenance instructions of the product, as well as the way of fixing minor faults that could appear.

It is recommended before the operation of the product to read carefully this manual in order to avoid damages caused by a misuse.

Do not lose this document, it should be accessible to any doubt that could appear by medical personnel.

Remember that a good use and maintenance are necessary for the proper operation of the product.

Each product incorporates an identification sticker with the serial number and the model. Keep these numbers so that they can be indicated to the dealer if necessary.

01.2 Serving request

For information of the correct interpretation of the instruction manual, the use, maintenance, installation and restoration of the product, please contact Promeba customer service T. 93 837 12 00, Fax 93082061008, email promeba@promeba.com or write to PROMEBA, S.L. - Ctra C-16 Km 59.5 · 08650 Sallent (Barcelona) · SPAIN.

01.3 Demolition

When the devices are no longer suitable for use, they must be correctly recycled according to whether it is electrical and electronic equipment, batteries or normal solid waste, following current regulations on demolition:

WARNINGS FOR THE CORRECT DISPOSAL OF THE PRODUCT IN ACCORDANCE WITH EC DIRECTIVE 2012/19/EU WEEE:



At the end of his life, the product must not be disposed as household waste. Can be taken to special recycling centers provided by local government, or return it to the dealer on purchase of a new device of the same type and used for the same functions. Dispose of the product separately avoids possible negative consequences for the environment and human health resulting from inappropriate disposal and allows to recover the materials in order to obtain significant savings in energy and resources. The symbol on the label indicates separate collection of electrical and electronic equipment.



WARNING

An incorrect disposal of electrical and electronic equipment could result in sanctions.

01.4 Intended purpose

The ELECTRIC STRETCHER product family is designed to effortlessly load any type of patient with litter or neonatal incubator in hospital and pre-hospital environments.

Promeba's products, stretcher Systems and stretcher chairs can be used by all groups of people who have received instructions and a training course directly from Promeba staff or from our business partners.















Further user-to-user instructions are also possible for those people who receive the certificate directly from Promeba. Personnel must be trained in the use of the product and in first aid procedures.

01.5 Contraindications and adverse effects

- Contraindications: None known.
- Adverse effects: None known.

01 INTRODUCTION

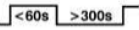
01.6 Legend of Symbols

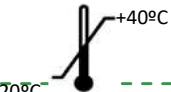
SYMBOL	EXPLANATION / DESCRIPTION
	MANUFACTURER symbol. This symbol is accompanied by the name and address of the manufacturer, adjacent to the symbol (PRODUCTOS METÁLICOS DEL BAGÉS S.L., Ctra. C-16 Km 59.5, 08650 Sallent (Barcelona)).
	Indicates the manufacturer's catalog number to identify the medical device. The synonyms for "catalog number" are "reference number" and "order number". PROMEBA, S.L. uses this symbol to set each internal reference for each configuration and business variant.
	Indicates the manufacturer's serial number to identify a specific medical device.
	Indicates the manufacturing date. The symbol must be accompanied by a manufacturing date (yyyy-mm), adjacent to the symbol.
	This symbol is not harmonized for medical devices. It is placed to inform that the product is a "Medical Device". Considering this symbol as not harmonized, the direct message / translation is also included to inform and identify the product as a "Medical Device" (see Labeling and IFU Illustrations)
	CE symbol without the intervention of a Notified Organism, as a Medical Device classified as Class I according to the EU Regulation 2017/745 on Medical Devices.
	This symbol is not harmonized for the Unique Device Identifier.
	Symbol "See instructions for use or operating instructions". This symbol is placed to report IFUs inside product boxes when the IFU brochure is included in the business presentation.
	Symbol "caution". This symbol is placed to alert the user to the need for important precautionary information in IFUs, such as warnings and cautions not otherwise found on the label.
	Waste symbol for electrical and electronic equipment "WEEE" (Waste Electrical and Electronic Equipment). Recycle: Electronic equipment. DO NOT THROW GARBAGE
	"Dangerous voltage" symbol. To warn of electricity.
	Symbol "Caution". For a general warning.
	"Double insulation" symbol. The protection of appliances marked with this symbol is ensured by double insulation and does not require a safety electrical connection to earth (ground).
	Cot duty cycle: 16.7% (less than 60 seconds on, more than 300 seconds off)
	Warning; crushing of hands
	Indicates the temperature limits. The upper and lower temperature limits should be indicated adjacent to the lower horizontal line

01 INTRODUCTION

01.7 Notices and warnings

NOTICES

- Improper usage of the product can cause injury to the patient or operator. Operate the product only as described in this manual.
- Do not modify the product or any components of the product. Modifying the product can cause unpredictable operation resulting in injury to patient or operator. Modifying the product also voids its warranty.
- Always set the stretcher load height to the proper stop height before operation.
- Always have a certified mechanic, familiar with ambulance vehicle construction, install the stretcher support. Consult the vehicle manufacturer before install the stretcher support. Make sure that the installation does not damage or interfere with the brake lines, oxygen lines, fuel lines, fuel tank or electrical wiring of the vehicle.
- Always charge the batteries before using the product. An uncharged or depleted battery may cause poor product performance.
- Only charge the stretcher's batteries with the charger supplied by PROMEBA, otherwise it could damage the batteries and will lose their warranty.
- Always clear obstacles that may interfere and cause injury to the operator or patient before operating the stretcher.
- Always remove the battery if the stretcher is not going to be used for an extended period of time (more than 24 hours).
- It is important to maintain a minimum of charge cycles each month to maintain the good capacity of the batteries.
- Do not leave the batteries uncharged for more than 2 MONTHS. They could stop working.
- Do not steam clean or ultrasonically clean the product.
- Do not clean, service, or perform maintenance while the product is in use.
- Always use authorized parts to avoid the risk of product damage.
- Always check hoses and lines regularly to avoid damage to the stretcher. Check and tighten loose connections. Hydraulic lines, hoses, and connections can fail or loosen due to physical damage, kinks, age and environment exposure.
- The use of accessories, transducers, and cables other than those specified or provided by the manufacturer, could result in increased electromagnetic emission or decreased electromagnetic immunity and result in improper operation.
- In repeatedly raising and lowering maneuvers of up to 20 uninterrupted cycles, we must make a mandatory stop for at least 15 seconds so that the electro-hydraulic system of the stretcher recovers.
- To load the stretcher, the rail must always be fully extracted outside the ambulance.
- The electronic system of the stretcher will automatically switch off if no operation has been carried out within 15 minutes.
- When the stretcher is fully loaded on the rail, it will stop after 3 seconds.
- Use adjustable stretcher cover for the stretcher bunk.
- The front wheels of the stretcher must remain locked when loading / unloading the stretcher. If not, important elements of the stretcher may be damaged.

01 INTRODUCTION

WARNINGS

- Always keep your hands clear of the moving parts when you load, unload or change the height position of the stretcher.
- Always use both hands when transport the stretcher.
- Do not attempt to operate the stretcher when is loaded on the stretcher support.
- Do not remove the battery when the stretcher is active.
- Always operate the stretcher when all persons are clear of the mechanisms. Entanglement in electric stretcher mechanisms can cause serious injury.
- Do not allow untrained assistants to assist in the operation of the product.
- Do not ride on the stretcher support.
- Do not transport the stretcher sideways to avoid the risk of tipping. Always transport the stretcher in a lowered position, head end or foot end first to minimize the risk of tipping.
- Always conduct the patient monitoring when the stretcher is idle-. If you hydraulically raise or lower the product you may temporarily affect electronic patient monitoring equipment.
- Do not leave the patient unattended. Hold the product while a patient is on the product.
- Do not apply wheel lock when a patient is on the product or when you move the product to avoid the risk of tipping.
- Do not use handrails as a patient restraint device.
- Always transport the stretcher at a lower height to reduce the risk of a stretcher tip. If possible obtain additional assistance or take alternate route.
- Always avoid high obstacles, such as curbing, steps, or rough terrain to avoid the risk of the product tipping over.
- Always use all the belts to secure the patient on the stretcher. An unfastened patient may fall from the stretcher.
- Do not attempt to open the battery pack for any reason, to avoid the risk of electric shock. If the battery pack case is cracked or damaged, do not insert it into the charger. Return damaged battery packs to a service center for recycling.
- Always avoid direct contact with a wet battery or battery enclosures. Contact may cause injury to the patient or operator.
- Always wipe the product with clean water and dry after cleaning. Some cleaning products are corrosive in nature and may cause damage to the product. Failure to properly rinse and dry the product leaves a corrosive residue on the surface of the product and may cause a premature corrosion of critical components.
- Always relieve pressure before you disconnect hydraulic or other lines. Escaping fluid under pressure can penetrate the skin and cause serious injury. Tighten all connections before you apply pressure. If an accident occurs, see a doctor immediately.
- Do not use bare hand to check for hydraulic leaks.
- The electrical installation of the rail must be carried out with the ambulance electrical systems disconnected.
- Do not lubricate the rail and / or stretcher when they are connected to the electrical network.
- Under no circumstances unlock the stretcher from the rail or manoeuvre it when the ambulance is moving. This can cause the stretcher to fall with physical risk for both the patient and those present in the cabin. This manoeuvre is completely prohibited. If you need to perform any manoeuvre on the patient that involves having to vary the height and, therefore, unlock the stretcher from its holder, it must be done with the ambulance completely stopped and located on a flat ground.

01 INTRODUCTION

01.8 Technical data sheet

MEASUREMENTS AND FEATURES // PC-750 STANDARD STRETCHER

LENGTH	2000 mm	OPERATOR REQUIRED	1
WIDTH	590 mm	LOAD HEIGHT	1095 mm
HEIGHT MIN/MAX	420-1300 mm	MAX. LOAD	350 Kg
WEIGHT	95 Kg	INPUT POWER SUPPLY	12 V _{DC} - 72W
INCLINATION OF THE BACK	75°	OUTPUT MOTOR CONSUMPTION	24 V _{DC} - 768W
FOWLER	17°	LOADING TIME	120 min
TRENDELEMBURG	30°	OP. TEMPERATURE	-20°/+40°

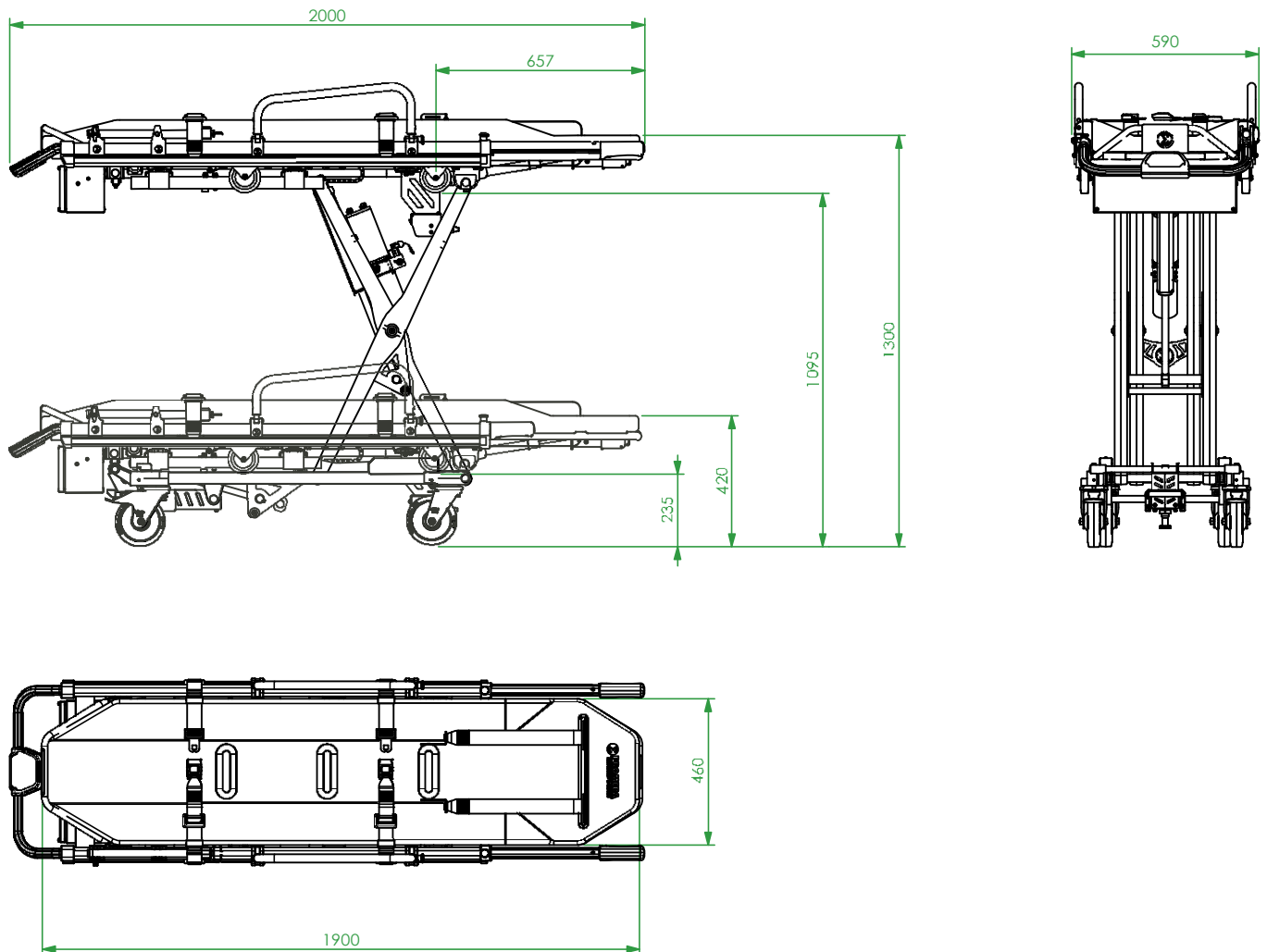

01 INTRODUCTION

MEASUREMENTS AND FEATURES // PC-751 ENGLAND STRETCHER

LENGTH	2150 mm	OPERATOR REQUIRED	1
WIDTH	590 mm	LOAD HEIGHT	1095 mm
HEIGHT MIN/MAX	420-1300 mm	MAX. LOAD	300 Kg
HEIGHT MIN/MAX HANDLES	860-1740 mm	INPUT POWER SUPPLY	12 V _{DC} - 72W
WEIGHT	95 Kg	OUTPUT MOTOR CONSUMPTION	24 V _{DC} - 768W
INCLINATION OF THE BACK	75°	LOADING TIME	120 min
FOWLER	17°	OP. TEMPERATURE	-20°/+40°
TRENDELEMBURG	30°		

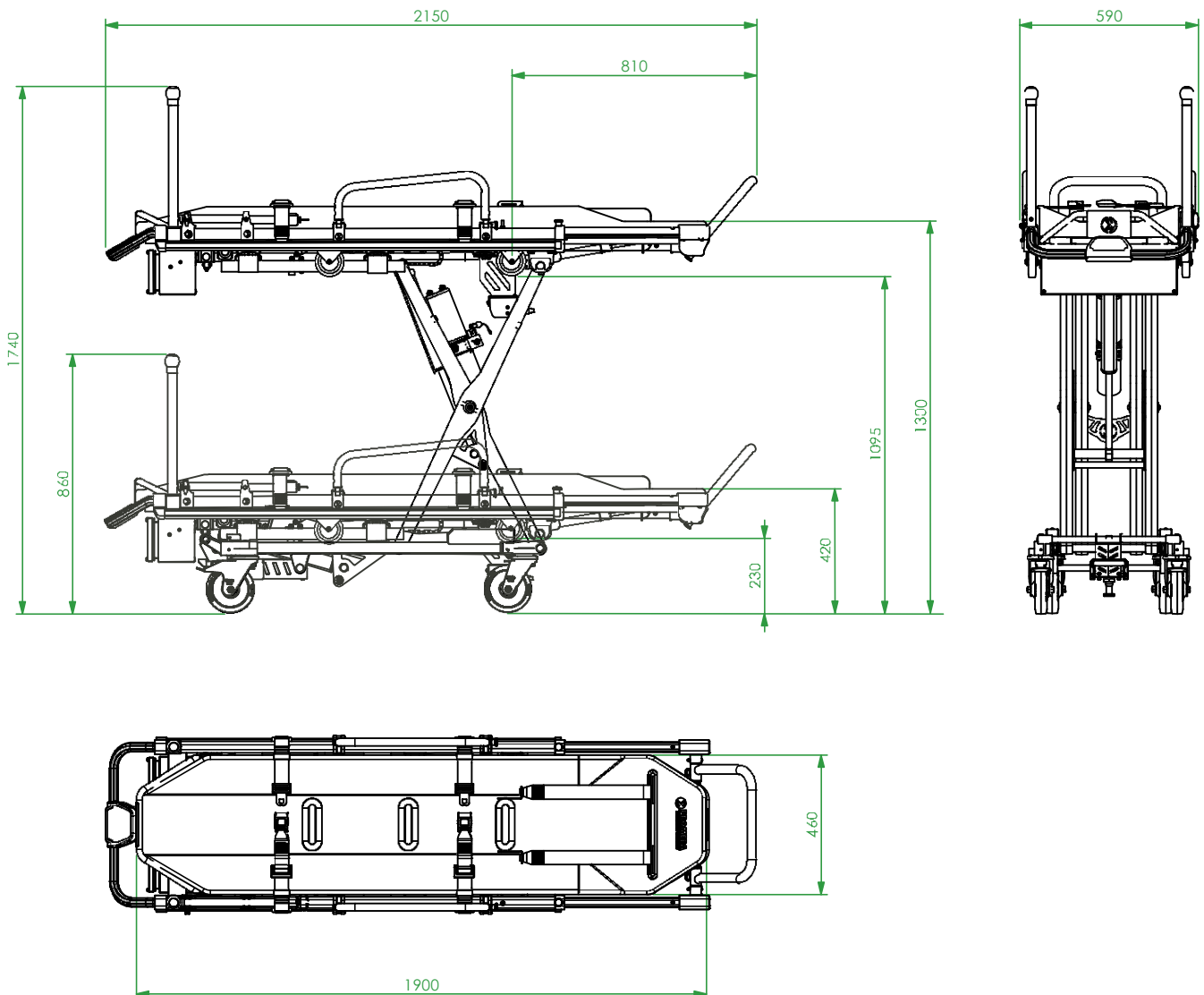

01 INTRODUCTION

MEASUREMENTS AND FEATURES // PC-755 INCUBATOR STRETCHER

LENGTH	2032 mm	MAX. LOAD	300 Kg
WIDTH	575 mm	INPUT POWER SUPPLY	12 V _{DC} - 72W
HEIGHT MIN/MAX	392-1257 mm	OUTPUT MOTOR CONSUMPTION	24 V _{DC} - 768W
WEIGHT	90 Kg	LOADING TIME	120 min
OPERATOR REQUIRED	1	OP. TEMPERATURE	-20°/+40°
LOAD HEIGHT	1095 mm		

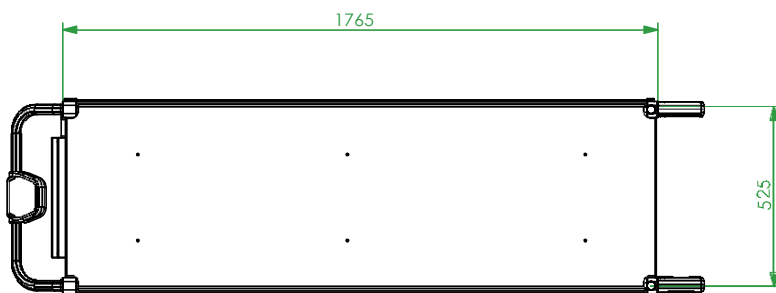
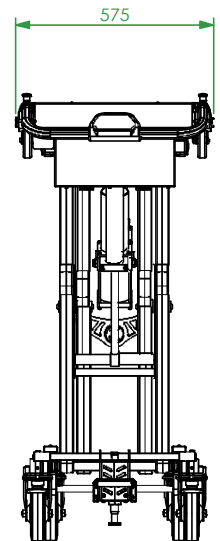
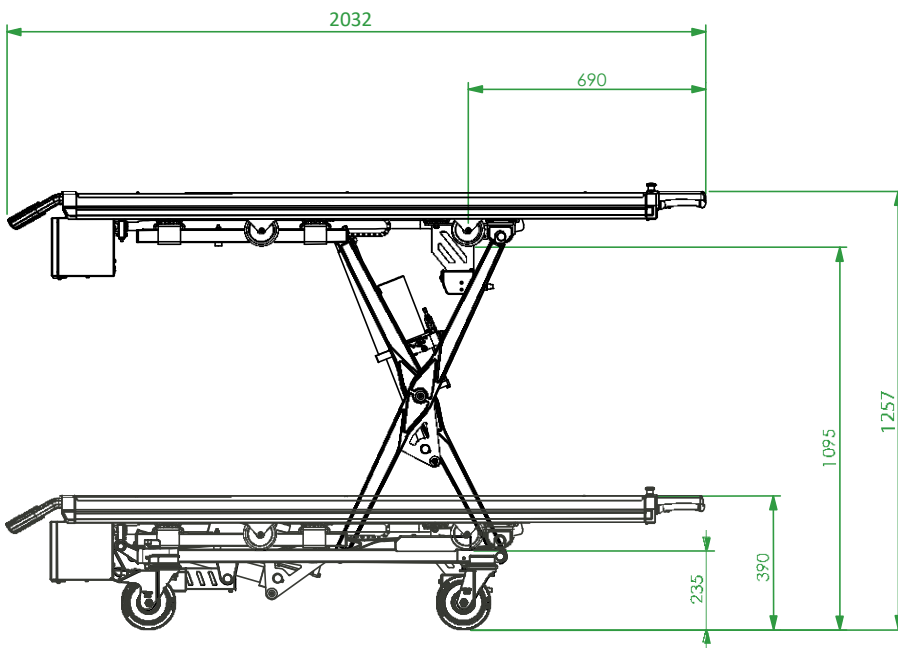

01 INTRODUCTION

MEASUREMENTS AND FEATURES // PB-720 SUPPORT WITH CABINET

LENGTH	2080 mm	WEIGHT	140 Kg.
WIDTH	600 mm	MAX. LOAD	425 Kg.
FRONT MOVEMENT	1640mm	OP. TEMPERATURE	-20° / 40° C
SIDE MOVEMENT	300 mm	OPERATOR REQUIRED	1

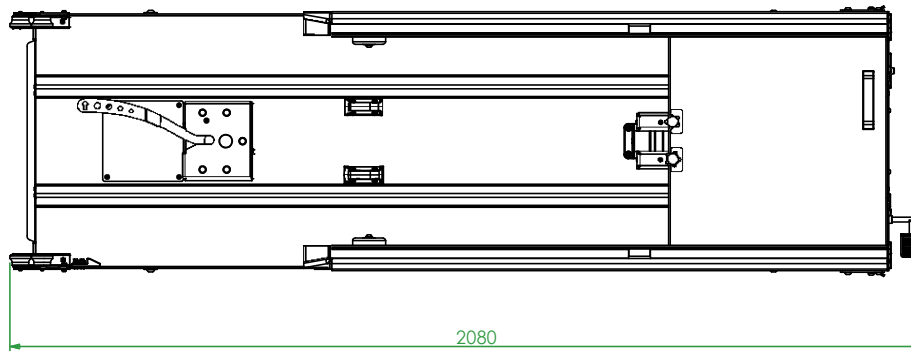
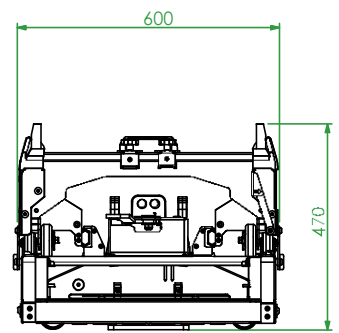
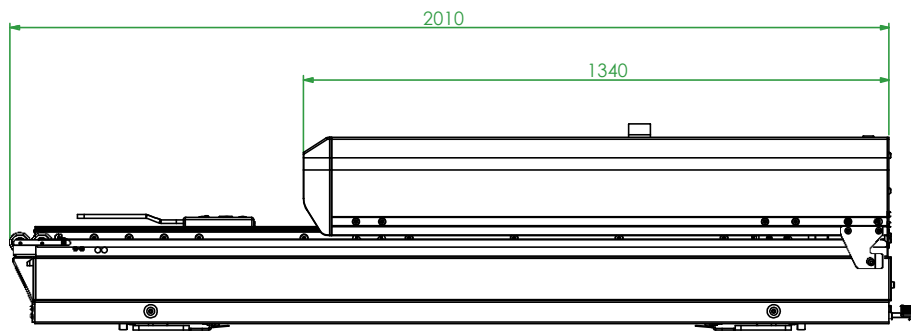

01 INTRODUCTION

MEASUREMENTS AND FEATURES// PB-725 SUPPORT WITHOUT CAB.

LENGHT	2045 mm	WEIGHT	117 Kg.
WIDHT	600 mm	MAX. LOAD	300 Kg.
FRONT MOVEMENT	1640mm	OP. TEMPERATURE	-20° / 40° C
SIDE MOVEMENT	300 mm	OPERATOR REQUIRED	1

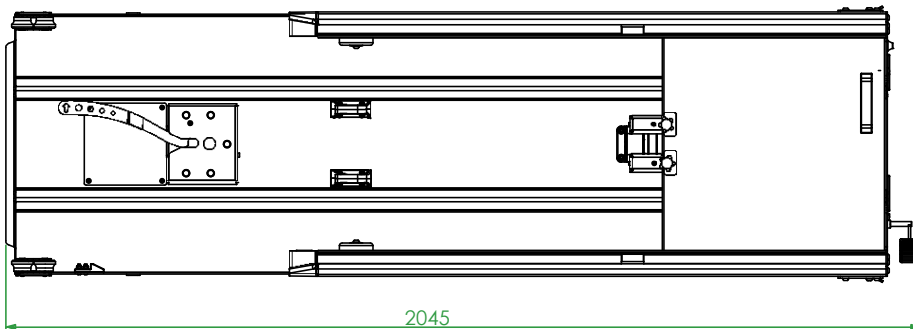
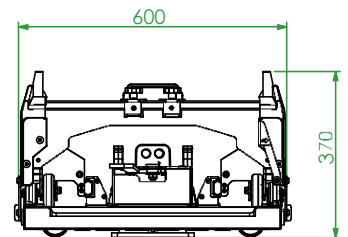
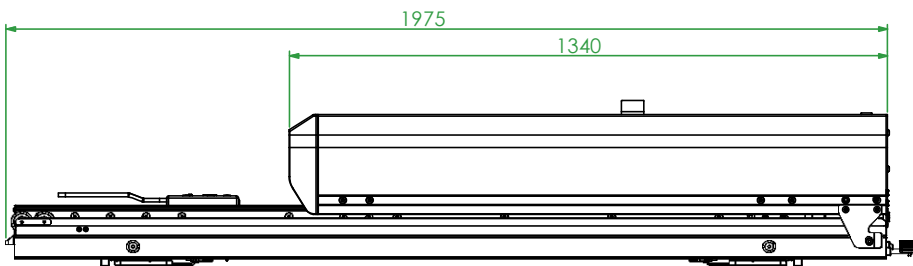



02 INSTALLATION

02.1 Transport and unpacking

First carefully remove the packaging to prevent the damage of the product. Take the wooden cover away and use a crane to move vertically.

1. Transport with a crane (high load)

- Thread tapes through the upper platform for its transport (as shown in graphs).
- Transport the load level following all the precepts and regulations for the transport of suspended loads.

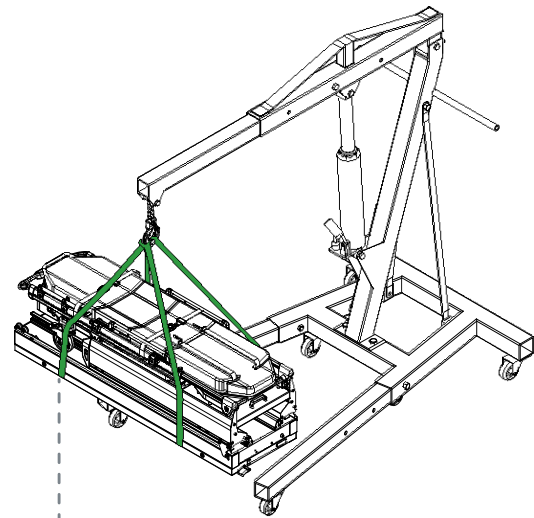

+ TRANSPORT WITH A CRANE
FIX THE TAPES TO LEVEL THE LOAD WEIGHT

2. Transport with a forklift

- Place a pallet or a flat surface under the stretcher support and transport it transversely.
- Do not load the stretcher support directly on the forklift without a pallet or flat support surface.
- Do not load the support stretcher longitudinally on the forklift if a sufficiently long base is not available.
- Every set has been thoroughly inspected leaving the factory. To ensure that it has not been damaged during the transport, it is requested to carefully examine the interior and exterior, and in case of finding any damage, communicate immediately to the installer.
- The stretcher and support set should be levelled for an optimum performance.

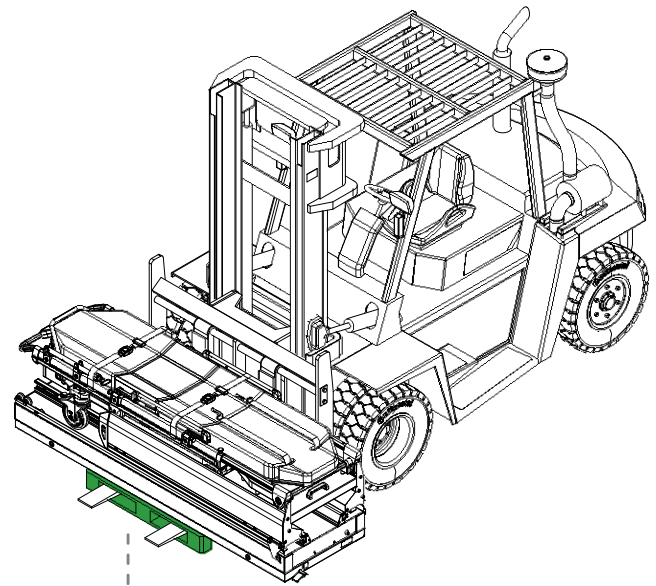

+ TRANSPORT WITH A FORKLIFT
USE ALWAYS A FLAT SUPPORT SURFACE

02 INSTALLATION

02.2 Anchorage points

Before putting the stretcher support into operation, ensure that each and every anchorage points are placed and clasped.

ANCHORE FOR PB-720 · PB-725
(8 anchorage points)

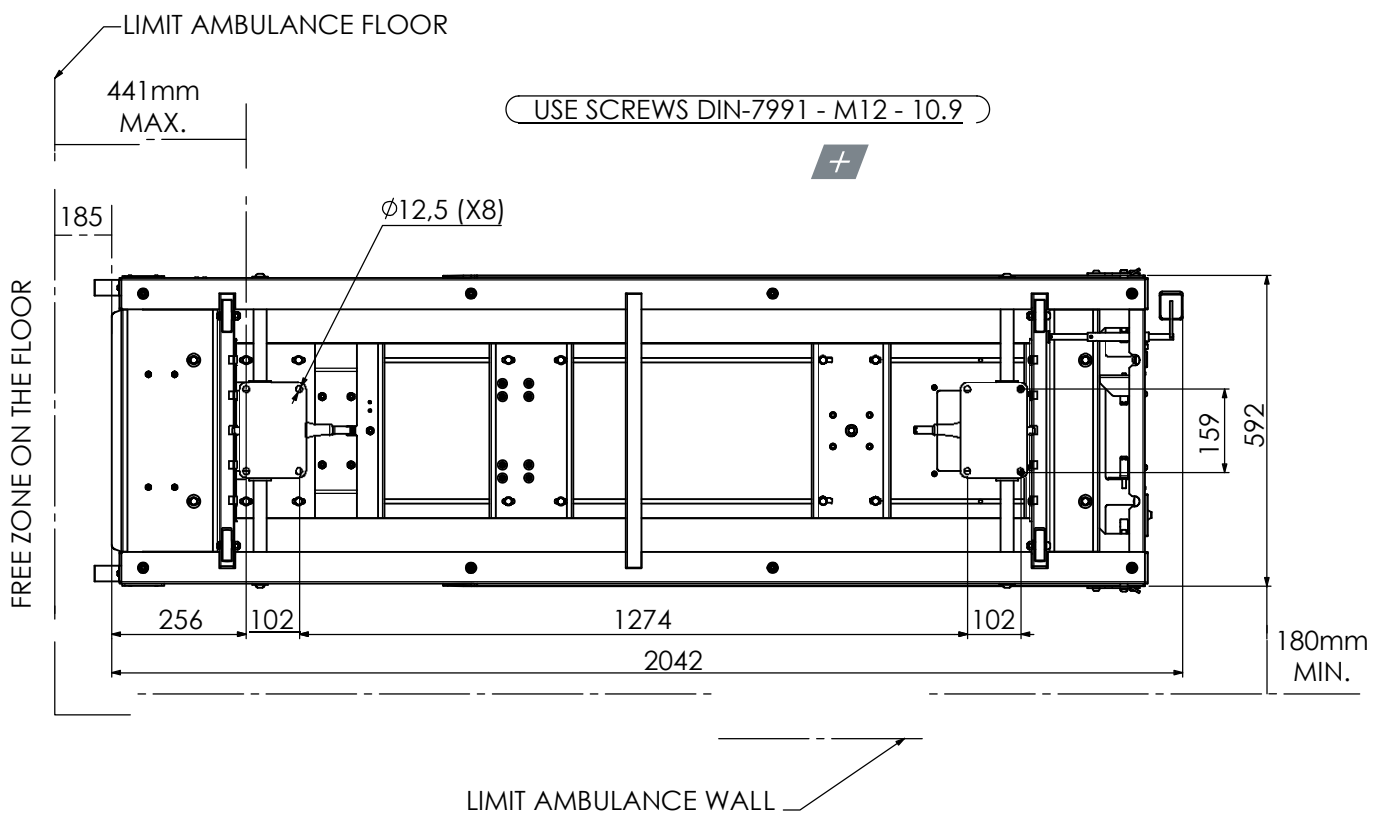

IMPORTANT FOR INSTALLATION

- Screws to be attached on the floor should be M12 according to norm DIN-7991 (8 units)
- Before drilling the ambulance floor, verify that the lateral movement of the stretcher support is placed at 0 position
- Install it upon the limits indicated on the drawing and make sure to fix the set on the reinforced chassis are
- The electric installation of the set must be completed with the electrical system of the ambulance disconnected

02 INSTALLATION

02.3 Connection to the mains power supply PB-720 / PB-725

To make the connection follow the steps below.

Be particularly careful when the connecting the stretcher support to the required voltage of 12V and do not leave cables in passageways and or moving elements. It can provoke breakages, cuts and system failures.

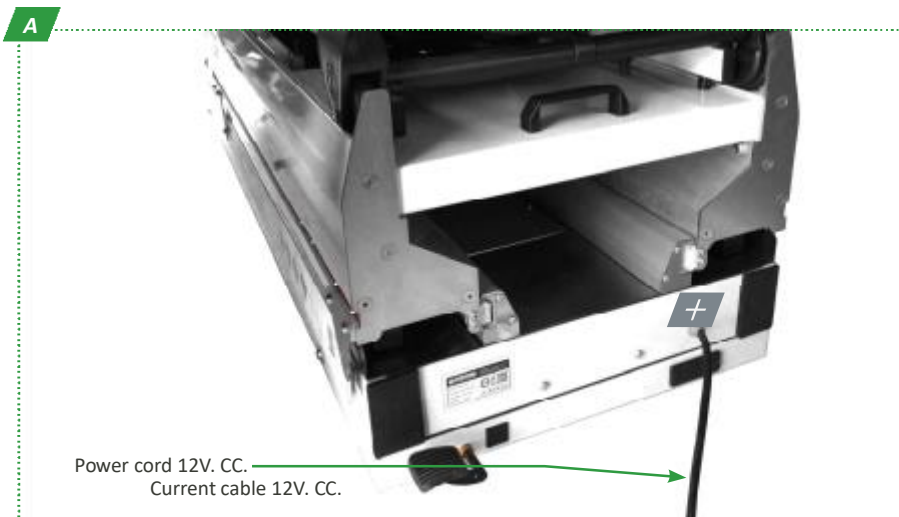

To make the connection locate the black cable placed on the front side of the support stretcher.

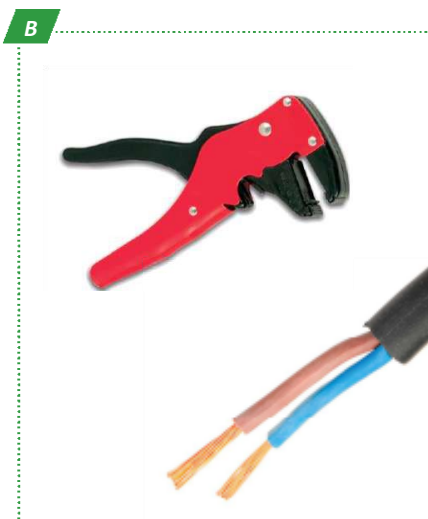

Remove the plastic end of the BROWN (+) y BLUE (-) cables with a thread peeler to make the connection.

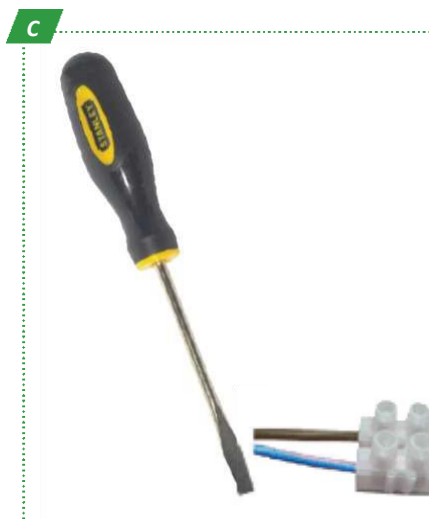

Use a power strip and a flathead screwdriver to connect the BROWN (+) y BLUE (-) wires together with the outlet of the ambulance.



Make sure you have the power line properly protected and ensure the power along the line is stable.

02 INSTALLATION

02.4 Stretcher's launch PC-750 / PC-751 / PC-755

To start using the electric stretcher it is necessary to charge the batteries. To do this, locate the external charger connector on the right side of the battery cabinet, on the back of the stretcher.

Using the charger supplied by PROMEBA, charge the batteries to their maximum charge level (approximately 30 minutes).



Connector for external charger



External charger for PROMEBA's batteries.



Charge only the batteries of the stretcher with the charger supplied by PROMEBA, otherwise the batteries could be damaged and lose their guarantee.



03 OPERATION

03.1 Commands of the STRETCHER PC-750

1. Foldable and reclining handrails
2. Harness belts on the backrest
3. Touch control panel in the middle
4. Batteries cabinet with lock
5. Four lockable wheels
6. Telescopic frame for maneuvering
7. Bed with fowler and trendelenburg
8. Folding and adjustable IV pole
9. Powerful LED lighting on the sides
10. Emergency strap
11. Belts with front locking push button
12. Automatic integrated charging system
13. Front wheel lock pedal



03 OPERATION

03.2 Commands of the ENGLAND STRETCHER PC-751

- 1. Foldable and reclining handrails
- 2. Harness belts on the backrest
- 3. Touch control panel in the middle
- 4. Batteries cabinet with lock
- 5. Four lockable wheels
- 6. Telescopic frame for maneuvering
- 7. Bed with fowler and trendelenburg
- 8. Folding and adjustable IV pole
- 9. Powerful LED lighting on the sides
- 10. Emergency strap
- 11. Belts with front locking push button
- 12. Automatic integrated charging system
- 13. Front wheel lock pedal
- 14. High handles

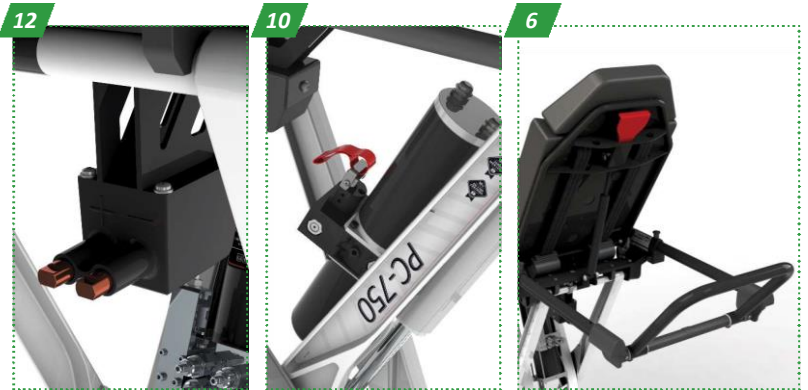

03 OPERATION

03.3 Commands of the INCUBATOR STRETCHER PC-755

1. Stainless steel tray for incubator
2. Touch control panel in the middle
3. Batteries cabinet with lock
4. Four lockable wheels
5. Telescopic frame for maneuvering
6. Powerful LED lighting on the sides
7. Emergency strap
8. Automatic integrated charging system

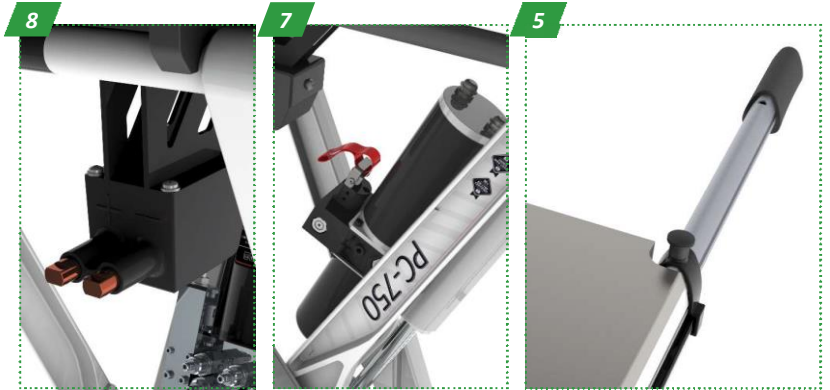

03 OPERATION

03.4 Commands of the SUPPORT PB-720

1. Pull-out lever for removable rail
2. Third point stretcher lock
3. Stretcher loading point
4. Stretcher central hooks
5. Push button to collect the removable rail
6. Ball bearing to support removable rail
7. Lever to collect the removable rail from inside of the ambulance
8. Side movement lever
9. Safety hooks to grip the stretcher
10. Scoop stretcher housing module

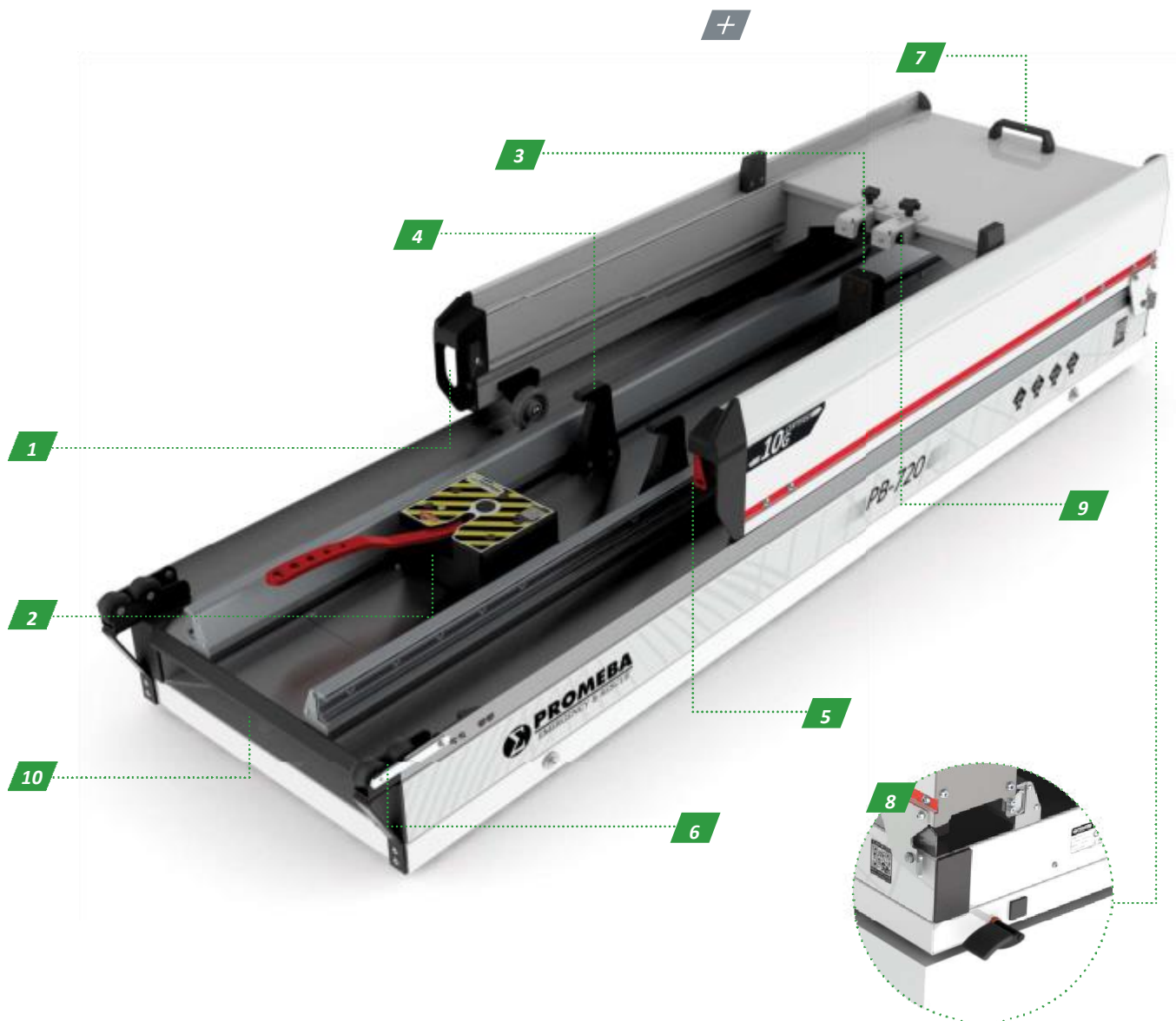

03 OPERATION

03.5 Commands of the SUPPORT PB-725

1. Pull-out lever for removable rail
2. Third point stretcher lock
3. Stretcher loading point
4. Stretcher central hooks
5. Push button to collect the removable rail
6. Ball bearing to support removable rail
7. Lever to collect the removable rail from inside of the ambulance
8. Side movement lever
9. Safety hooks to grip the stretcher
10. Extra low rail module

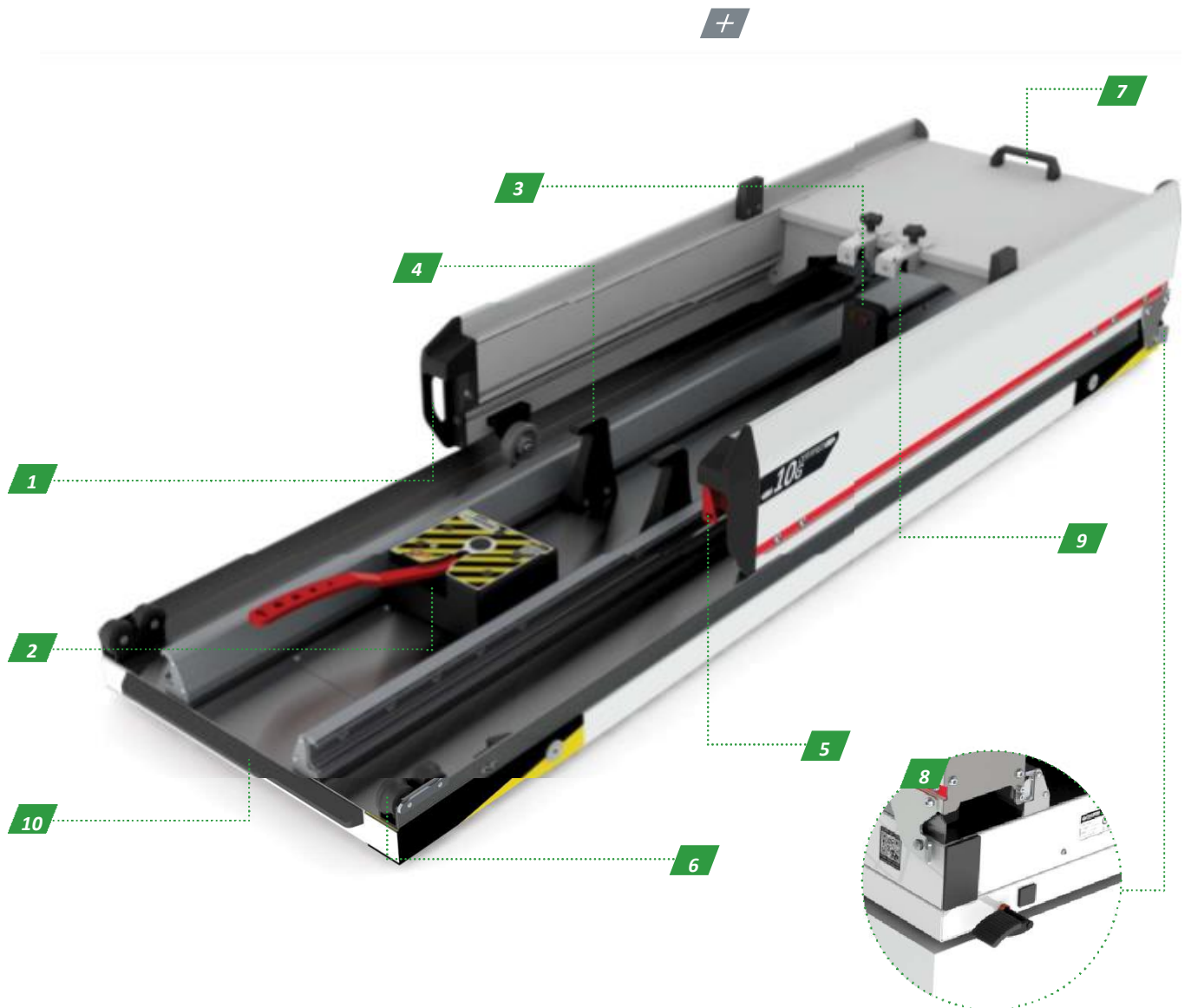

03 OPERATION

03.6 Elements of the manual system - STRETCHER PC-750 / PC-751 / PC-755

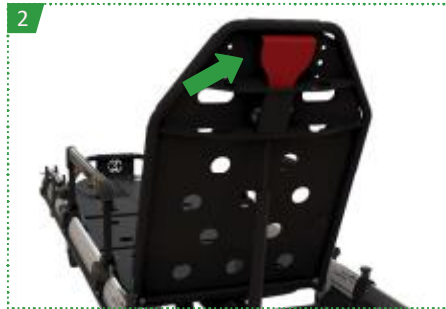

2 Adjust the backrest inclination
Have 6 positions. Pressure the red handle and company the backrest to desire position.

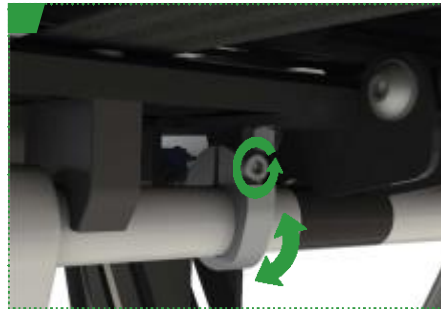

3 Adjust maximum high of the stretcher
To adjust the maximum high of the stretcher loosen the screw and spin to desired position.



4 Waterproof batteries cabinet
To open the batteries cabinet, unscrew the 4 screws.

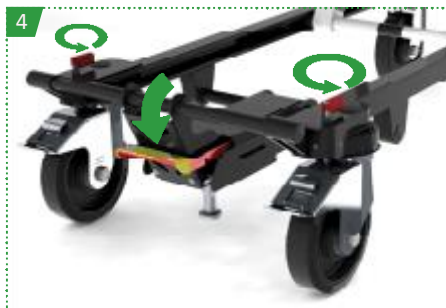

5 Four lockable wheels
Spin the red handle to block or unblock the turn of the stretcher's wheels.

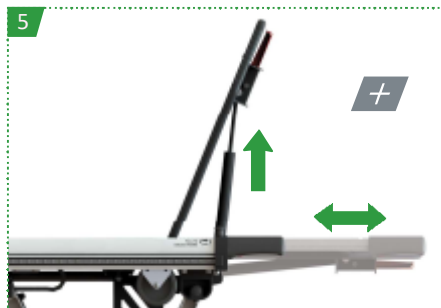

6 Telescopic frame
Place the backrest in the vertical position, trigger lateral knob and pull out or close the frame.

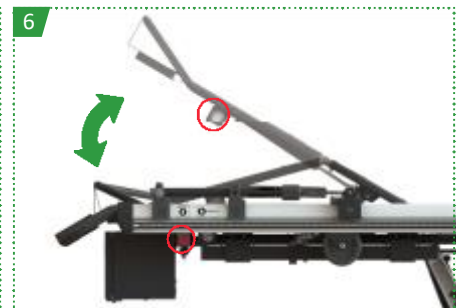

7 Bed with fowler and trendelenburg position
The bed set has two red buttons for adjust the position.

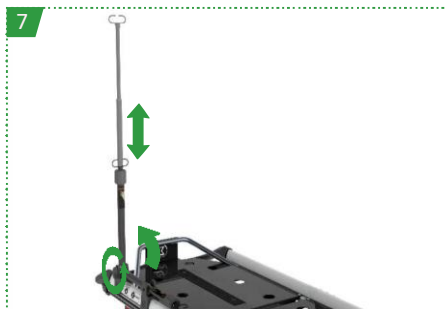

8 Folding and adjustable IV pole included
Spin the wing nut to raise the IV pole and twirl the upper ring. Unfold it.



9 Powerful LED lighting on the sides
Press the button LIGHTS from control panel for vate the lights in the blinking or fixed mode.



10 Emergency strap for lowering the stretcher
If you had to fold the stretcher in the manual , pull the emergency strap to fold it.



11 Belts with front locking push button
To unfasten the belts, push the red button. You must always fasten the patient.



12 Automatic integrated charging system
When you keep the stretcher on the support, the batteries of the stretcher will start to charge.



13 Connector for external charger
The stretcher has a connector on the side of the battery box to charge it with an external charger



Cot duty cycle: 16.7% (less than 60 seconds on, more than 300 seconds off)



03 OPERATION

03.7 Elements of the manual system - **STRETCHER SUPPORT PB-720 / PB-725**

LATERAL DISPLACEMENT

Hand lever

Operate the lever located on the rear of the right side of the support, making a slight effort with foot and accompanying that movement by sliding with hands.

The total lateral displacement is **300 mm**.

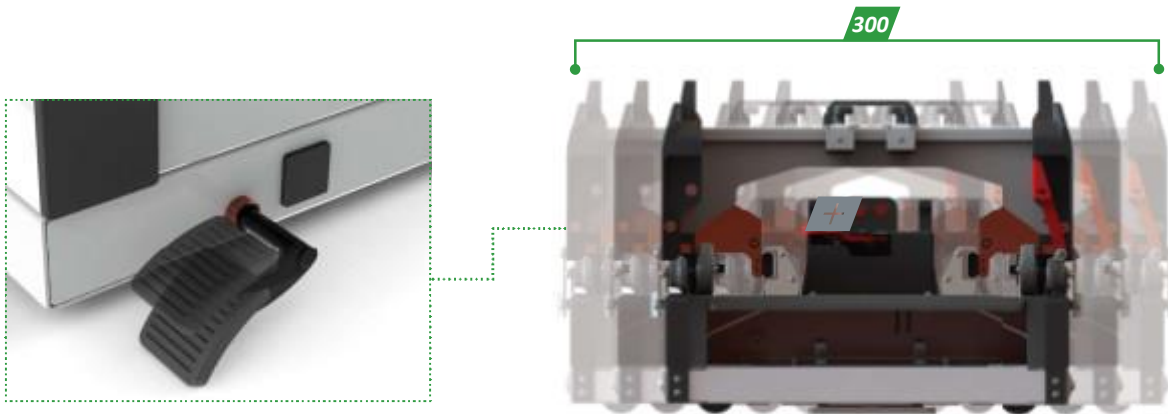

LONGITUDINAL DISPLACEMENT

Hand lever

Operate the lever located on the front of the right side of the support by applying a slight effort with the foot and accompanying this movement by sliding your hands.

The total longitudinal displacement is **1640 mm**.

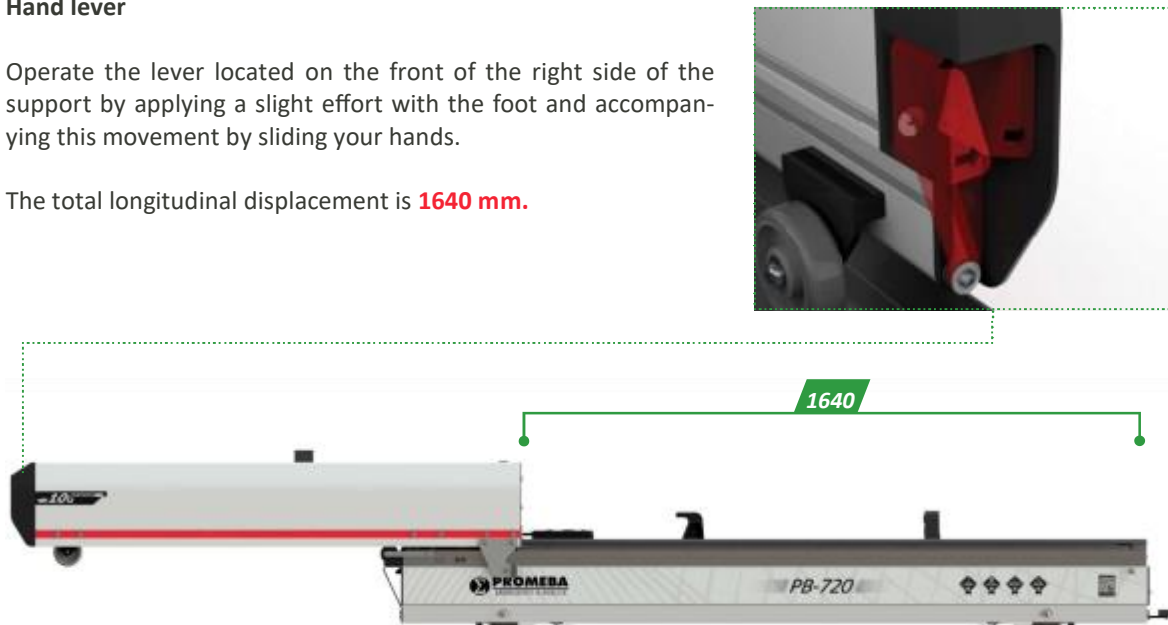

To load the stretcher, the support stretcher always must be placed totally pull out of the ambulance.

03 OPERATION

03.8 Loading and unloading operation

Starting from the position in which the support has been left after the loading of the stretcher into the ambulance (1):

UNLOADING

- Pull the lever of the anchor point towards the left (A).
- Automatically the stretcher will be free. Push it out the ambulance (B) until the support are totally extract (2).
- Use the control panel to power the stretcher. WAIT 2 SECONDS to activate the system and later push the UP button (C).
- Once the stretcher will be in its highest position, which will be free (4).
- Move away the stretcher in straight line until being completely out of the support.
- Again, pick the support up into the ambulance by the lever placed on right side (C).

LOADING

- Pull the support out the ambulance by lever of the anchor point (A). · 
- Push the support by lateral handles until its maximum.
- Move the stretcher closer towards the support in straight line (5) make sure the wheels are placed like the image (D).
- Push the DOWN button on the control panel of the stretcher (E) and after push right lateral lever of the support (C) to put the set into the ambulance.
- Secure the stretcher is fasten on the anchor point (A) and anchor point is on close position.
- Verify the stretcher are charging, pushing the POWER button.

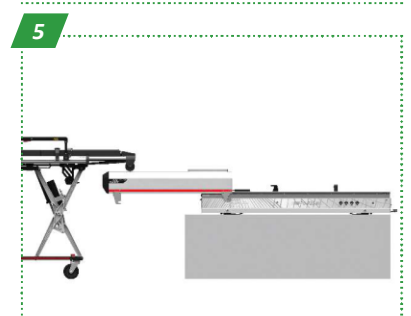
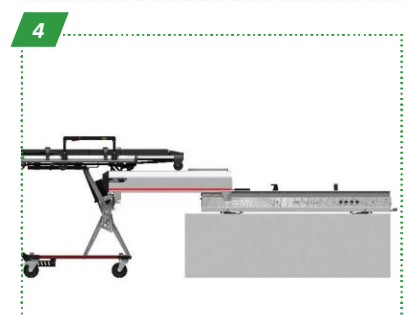
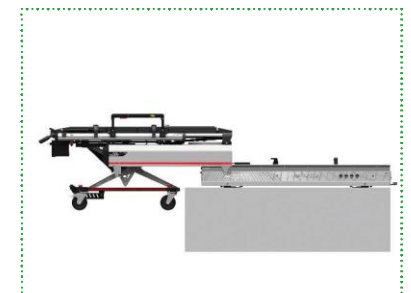
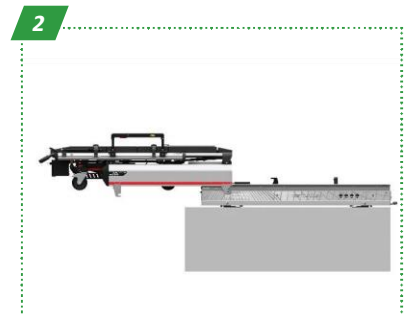

- The front wheels of the stretcher must **remain locked** when loading / unloading the stretcher. If not, important elements of the stretcher may be damaged.
- When the stretcher is fully loaded on the rail, it will stop after 3 seconds.

03 OPERATION

03.9 Control panel

CONTROL PANEL FUNCTION

All the electrical functions of the stretcher are controlled from the touch control panel placed on the back of the stretcher.

See its functions in the following graphic:

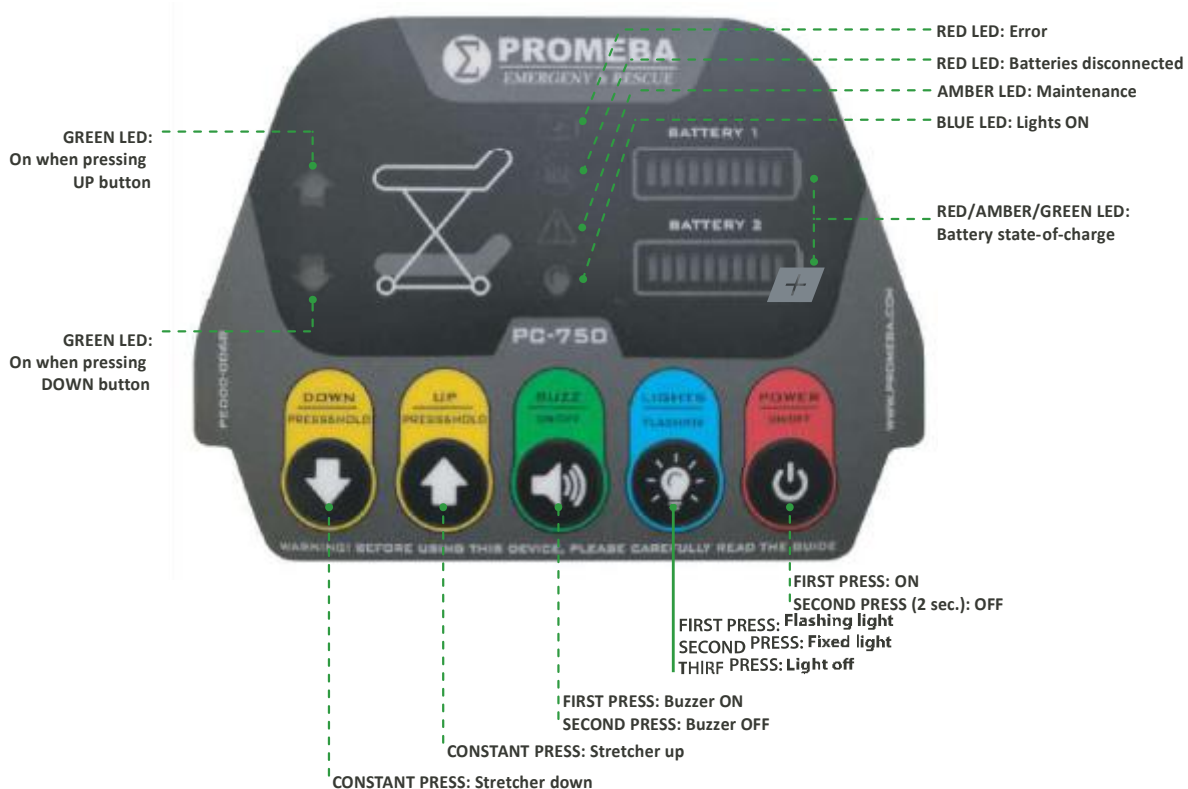

BATTERY LED: the duration of the batteries is 4 months if the stretcher is stopped, 2 weeks if it is on but without maneuvering or 100 maneuvers with weight.



MAINTENANCE LED: the amber light will come on after 3,000 hours of use to perform maintenance on the stretcher. In that case, you should contact your distributor or PROMEBA. **If 4000 hours of operation are exceeded, the ERROR LED will light.**

ERRORS KEY OF CONTROL PANEL

The led indicator of batteries status indicates possible errors of the system. In the following table, it is described the error according to its combination:

1. ERROR OF CONNECTION BETWEEN STRETCHER AND SUPPORT
2. ERROR FOR ELECTRIC SUPPLING ON THE SUPPORT
3. ERROR FOR OVERCHARGING BATTERIES
4. ERROR TIMEOUT FOR LOADING
5. ERROR MOVING UP FOR EXCESSIVE TIME
6. ERROR MOVING DOWN FOR EXCESSIVE TIME
7. ERROR IN CONTROL DRIVER OF STRETCHER
8. ERROR IN ENGINE TO EXCEED MAX. INTENSITY
9. ERROR IN ENGINE FOR LOW TENSION
10. ERROR FOR EXCEED LOAD



03 OPERATION

03.10 Breakdowns

HYDRAULIC SYSTEM FAILURE

In case of failure of the hydraulic system, it has a strap that allows the stretcher to be folded manually. To do this, locate the strap on the top of the actuator:

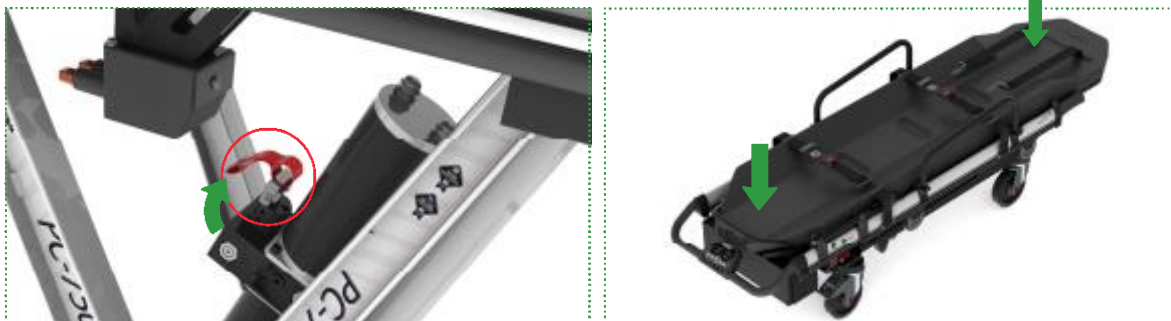

Pull the strap and the stretcher will descend until its lower position. 

Once the stretcher is folded, you should proceed to disassemble the safety hooks of the support as shown in the picture.

Once the stretcher is loaded into the support, you should place safety hooks in its initial position.

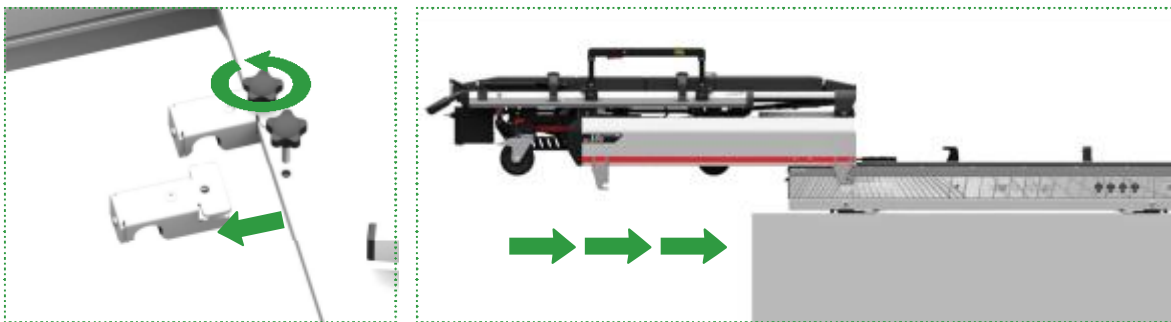

REMOVING THE BATTERY

In case of failing one of the batteries, the stretcher will work perfectly.

The system is prepared to work with one battery. The second one will be come in automatically when the control software detects that the first battery is about to run out.

However, if you have to change the batteries, you should proceed to open the compartment by unscrewing the four screws. Loosen the side screws that secure the battery holding cover and push it upward to remove the batteries.

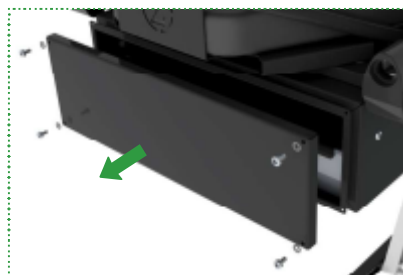

Batteries are delivered with a minimum charge. Before using the stretcher, you should previously charge the batteries with the external charger supplied with the stretcher to its maximum charge level. For a full charge, you should wait about 30 min.

03 OPERATION

03.11 Troubleshooter

COD.	ERROR'S DESCRIPTION	POSSIBLE CAUSE	POSSIBLE SOLUTION
1	- VOLTAGE BATTERY IS LESS THAN 3V - THEY ARE DAMAGED OR DISCONNECTED	- BATTERIES DISCONNECTED - BATTERIES DAMAGED	- BATTERIES PROPERLY CONNECTING - CHECK CABLE CONNECTION BATTERIES WITH ELECTRIC PLATE - REPLACE BATTERIES
2	- VOLTAGE BATTERY IS LESS THAN 34V	- OVERCHARGE DURING THE CHARGING BATTERIES OV	- COOL THE BATTERIES DURING 3/4 HOURS - USE THE CHARGER SUPPLIED BY PROMEBA - REPLACE BATTERIES FOR NEW ONES
3	- THE STRETCHER IS NOT RECEIVE VOLTAGE FROM AMBULANCE	- FAIL CONNECTION STRETCHER-SUPPORT - AMBULANCE'S BATTERY DISCONNECTED OR DAMAGED - POWER CABLES WRONG WAY CONNECTED BETWEEN SUPPORT AND AMBULANCE - ONE OF TERMINALS COPPER OF THE STRETCHER	-- CHECK TERMINAL CONNECTION BETWEEN STRETCHER-SUPPORT - CHARGE THE BATTERIES OR REPLACE FOR NEW ONES - CHECK THE CABLE CONNECTION BETWEEN STRETCHER-SUPPORT-AMBULANCE - CHECK TERMINAL CONNECTION OF THE STRETCHER GOING INTO AND LEAVING THE ACCOMMODATION
4	- VOLTAGE BATTERY IS LESS THAN 18V	- BATTERIES ARE DISCONNECTED	- CHARGE BATTERIES UNTIL ITS MAXIMUM LEVEL
5	- THE STRETCHER GETS THE VOLTAGE THROUGH TERMINAL CONNECTION OF THE SUPPORT, BUT THEY HAVE NOT BEEN PRESSED	- THE STRETCHER IS NOT PROPERLY ENTERED IN THE SUPPORT - FAIL IN MICROSWITCH	- ENSURE THE STRETCHER HAS ENTERED WELL INTO THE SUPPORT AND THE CONNECTION TERMINAL ARE WELL CONENCTED - CHECK THE STATUS OF MICROSWITCH
6	- BATTERIES ARE NOT DETECTED	- BATTERIES DISCONNECTED - BATTERIES CONNECTION DAMAGED - BATTERIES CHARGE VERY LOW	- ANCHOR WELL THE BATTERIES TO ITS BASE - REPLACE FOR NEW BATTERIES - CHARGE THEM WITH EXTERNAL PROMEBA'S CHARGER
7	- FAIL IN THE DRIVER OF ENGINE	- CONTACT WITH TECHNICAL SERVICE	- CONTACT WITH TECHNICAL SERVICE
8	- INTENSITY ABOVE 48V	- STRETCHER WITH OVERLOAD OF WEIGHT - BATTERIES UNCHARGED - THE STRETCHER NOT UP/DOWN GENTLY	- NOT LOAD THE STRETCHER WITH MORE THAN 350KG - CHARGE THEM WITH EXTERNAL PROMEBA'S CHARGER - SEARCH POSSIBLE SCRATCHS, INTERFERENCE OR LOCKED PIECES IN THE STRETCHER
9	- VOLTAGE IS LESS THAN 15V	- STRETCHER WITH OVERLOAD OF WEIGHT - BATTERIES UNCHARGED - THE STRETCHER NOT UP/DOWN GENTLY	- NOT LOAD THE STRETCHER WITH MORE THAN 350KG - CHARGE THEM WITH EXTERNAL PROMEBA'S CHARGER - SEARCH POSSIBLE SCRATCHES, INTERFERENCE OR LOCKED PIECES IN THE STRETCHER
10	- FAIL IN CHARGING PROCESS	- CONTACT WITH TECHNICAL SERVICE	- CONTACT WITH TECHNICAL SERVICE



IMPORTANT CONSIDERATION

- The electrical system of the stretcher will automatically turn off in 15 minutes if there are not make any operation.
- In manoeuvre of up and down repeatedly to 20 cycles continuously, you should make a mandatory stop for at least 15 seconds for electro-hydraulic system of the stretcher recovers.
- It is recommended to remove the two batteries if the stretcher will spend long periods of inoperability.
- It is important to maintain a minimum of loading cycles every month to keep the good capacity of the batteries.
- **Not leave without charge the batteries more than 2 MONTHS. It is possible they will stop working.**



04 MOUNTING AND COMPONENTS

04.1 Main exploded view

STRETCHER

PC-750 / PC-751 / PC-755

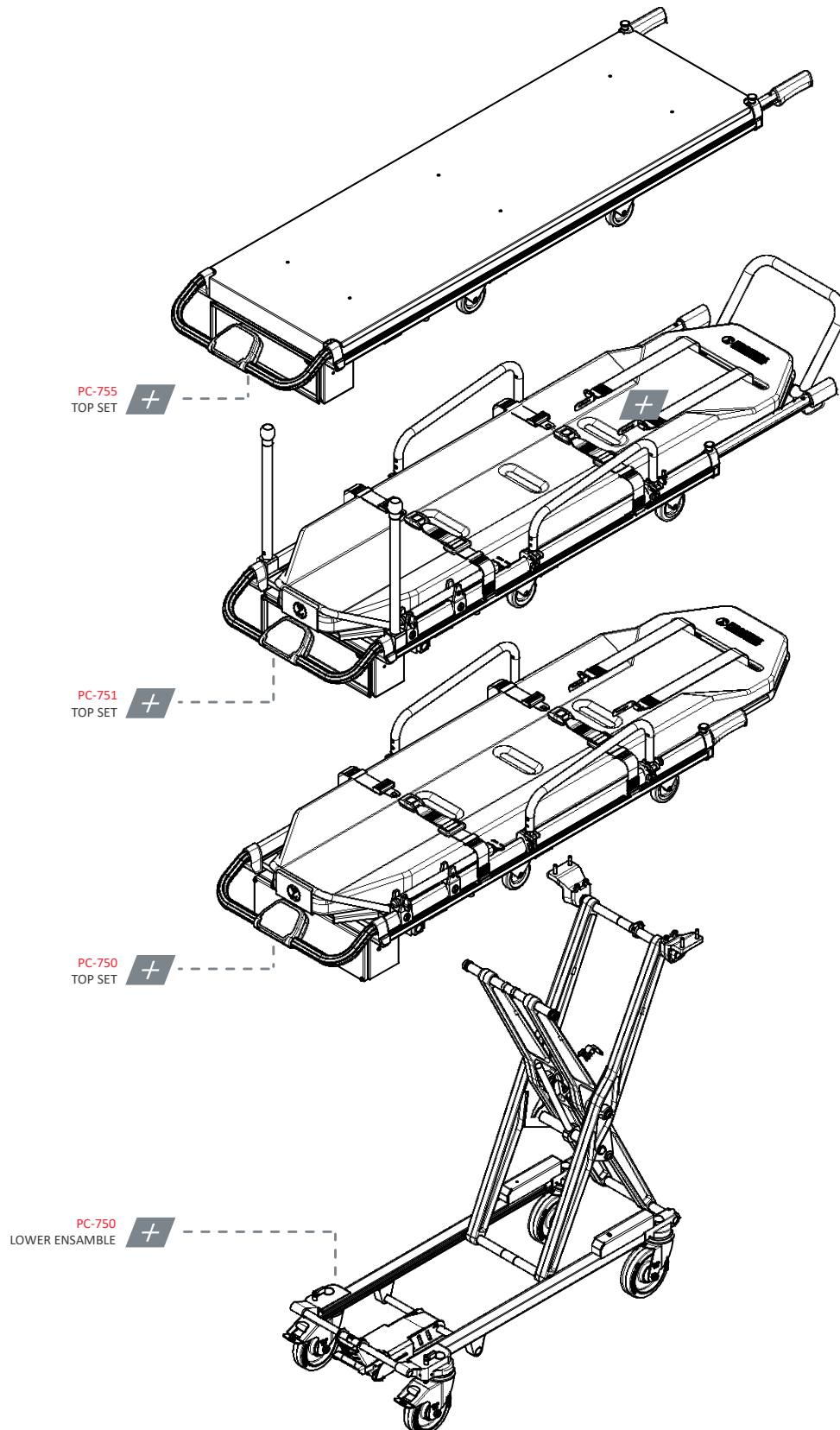

When ordering spare parts, please indicate the **color** of the stretcher for which it is intended

04 MOUNTING AND COMPONENTS

04.2 Exploded view

LOWER ENSAMBLE

PC-750 / PC-751 / PC-755

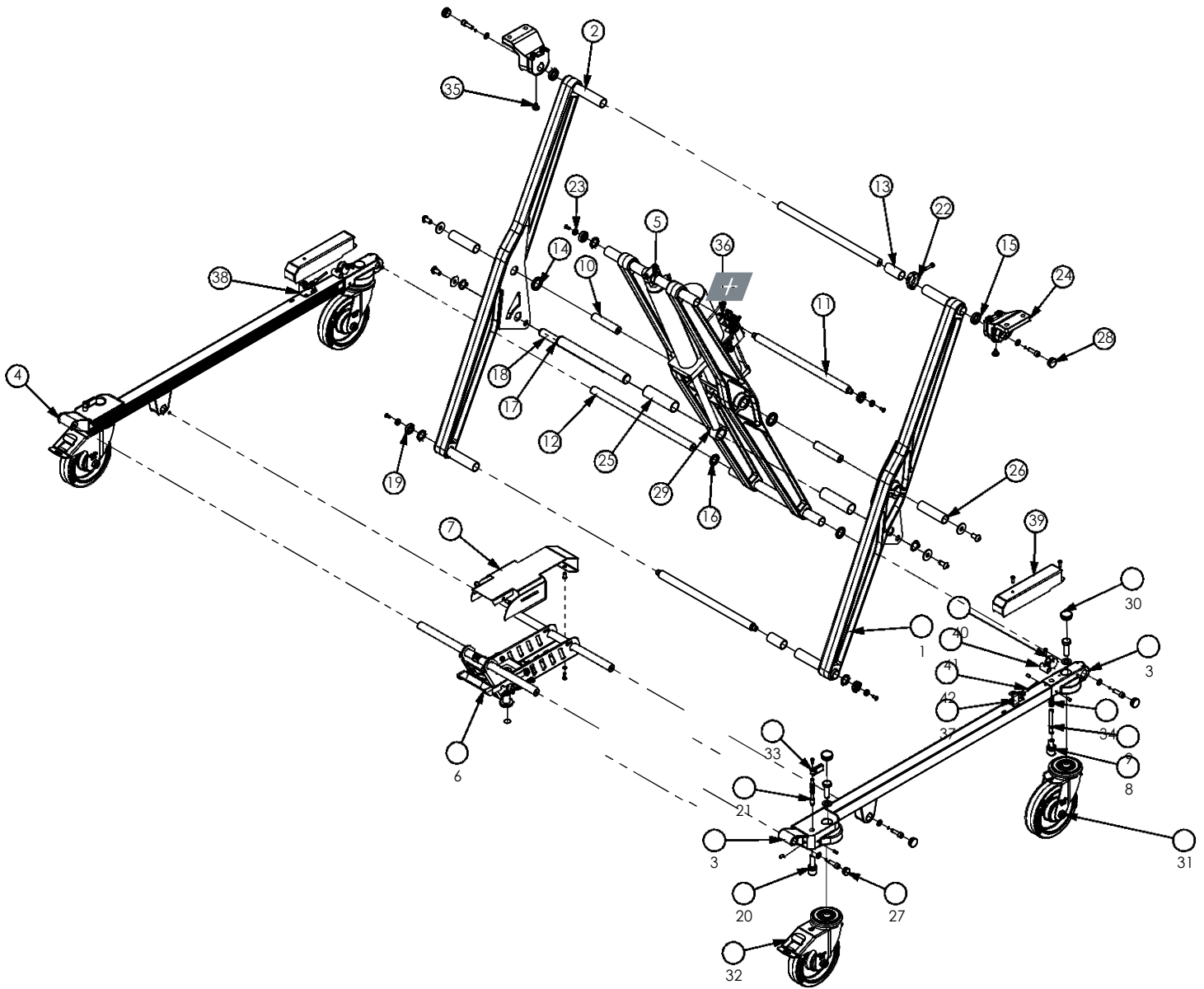

04 MOUNTING AND COMPONENTS

04.2 Bill of materials: LOWER ENSAMBLE PC-750 / PC-751 / PC-755

ELEMENT Nº	CODE - DESCRIPTION	QUANTITY
1	PC7500-06002 - Subconjunt pota exterior dreta	1
2	PC7500-05002 - Subconjunt pota exterior esquerra	1
3	PC7500-04002 - Subconjunt base rodes dret	1
4	PC7500-03002 - Subconjunt base rodes esquerra	1
5	PC7500-07002 - Subconjunt pota interior	1
6	PC7500-08000 - Conjunt tercer punt con pedal debloque	1
7	PC7500-08072 - Embellidor tercer punt camilla electrica	1
8	PC7500-01311 - CASQUELL BLOQUEIG RODA DAVANTERA	2
9	PC7500-01321 - BALDA BLOQUEIG RODA DAVANTERA	2
10	PC7500-01010 - Eix Interior gir central conjunt potes	2
11	PC7500-01020 - Eix Interior gir conjunt potes	2
12	PC7500-01050 - Eix exterior gir conjunt potes	2
13	PC7500-01030 - Casquell nylon central conjunt gir potes exterior	2
14	PC7500-01180 - Casquell nylon eix central gir potes	2
15	PC7500-01210 - Casquell nylon lateral conjunt gir potes superior	2
16	PC7500-01040 - Casquell nylon lateral conjunt gir potes exterior	6
17	PC7500-01070 - Eix gir suport actuador	1
18	PC7500-01082 - Eix anclatge ganxos rail central	1
19	6001ZZ - Rodament de boles sellat 12x28x8mm	4
20	PC6500-01311 - CASQUELL BLOQUEIG RODA POSTERIOR	2
21	PC6500-01321 - BALDA BLOQUEIG RODA POSTERIOR	2
22	PC7500-01090 - Regulador micro altura maxima	1
23	PC7500-01100 - Disc apoio xació coixinets	4
24	PC7500-01112 - Anclatge xació giro superior potes exteriors	2
25	PC7500-01132 - Tub centratge vasteg actuador	2
26	PC7500-01140 - Casquell intermitg conjunt potes exterior	2
27	TAP-PLASTØ20 - TAPON PLASTICO FINAL Ø20 - Mod. 17-20	2
28	TAP-PLASTØ25 - TAPON PLASTICO FINAL Ø25 - Mod. 17-25	6
29	PC7500-01120 - Vasteg actuador hidraulic HC1001028	1
30	TAP-PLASTØ30 - TAPON PLASTICO FINAL Ø30 - Mod. 17-30	4
31	PC7500-01150 - Conjunt roda giratoria sense fre	2
32	PC7500-01160 - Conjunt roda giratoria amb fre	2
33	PC7500-02170 - Maneta bloqueig rodes plastic	2
34	PC6500-01340 - molla bloquejador pota	4
35	TOPE-PLASTØ16 - Tope plastic negro FORTAPS REF. 32	2
36	PC7500-01200 - Conjunt grup actuador hidraulic HC1001028 v6	1
37	PC7500-08092 - Suport cable davanter dreta	1
38	PC7500-08102 - Suport cable davanter esquerra	1
39	PC7500-08104 - Tapa davantera subconjunt pota	2
40	PC7500-01331 - EXCÈNTRICA ACTUADOR DESBLOQUEIG	2
41	PC7500-01341 - Casquello tope actuador desbloque	2
42	PB4100-04840 - Tensor regulable	2

04 MOUNTING AND COMPONENTS

04.3 Exploded view

THIRD LOCKING POINT

PC-750 / PC-751 / PC-755

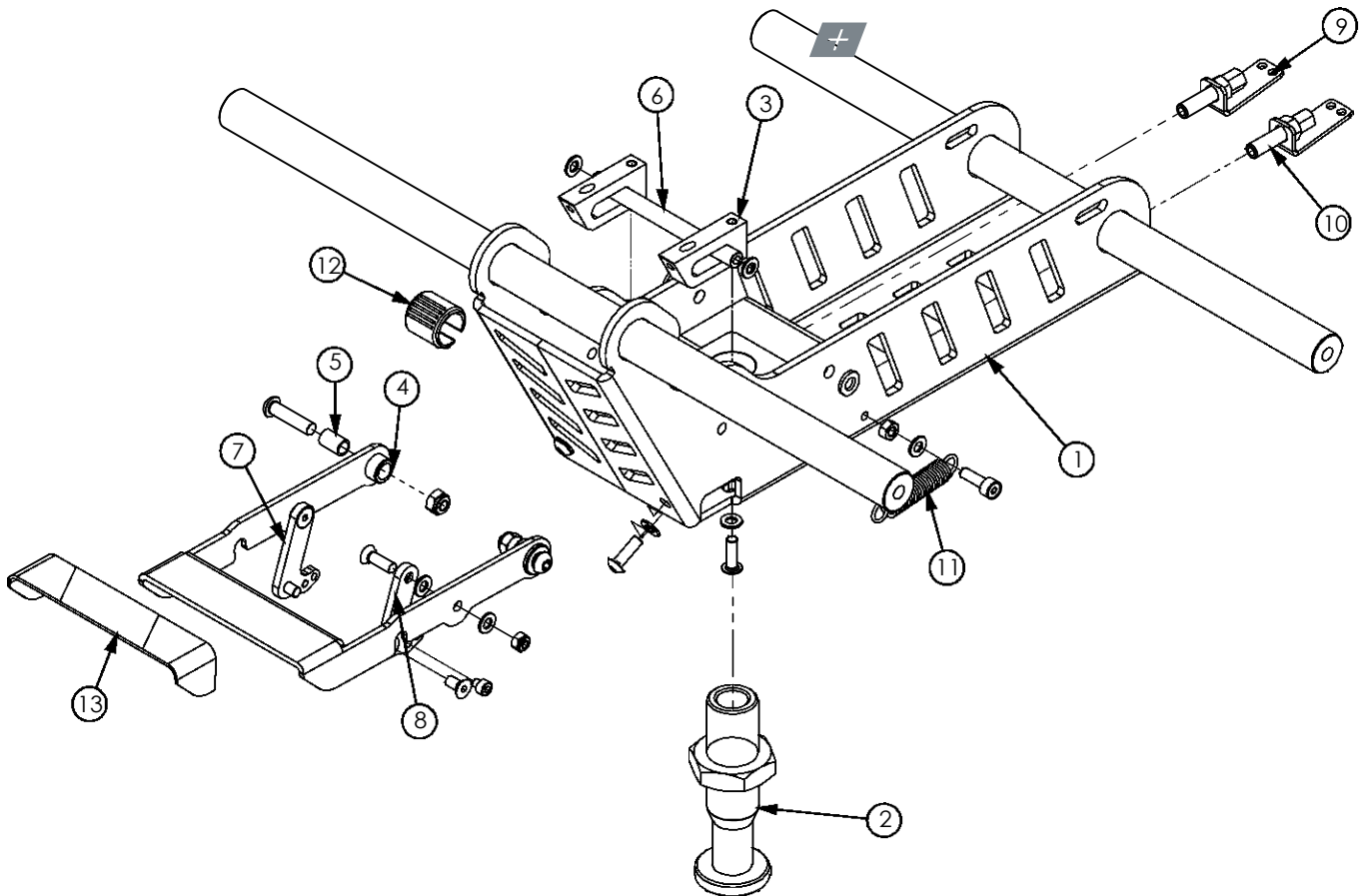

04 MOUNTING AND COMPONENTS

04.4 Exploded view

UPPER ENSAMBLE

PC-750

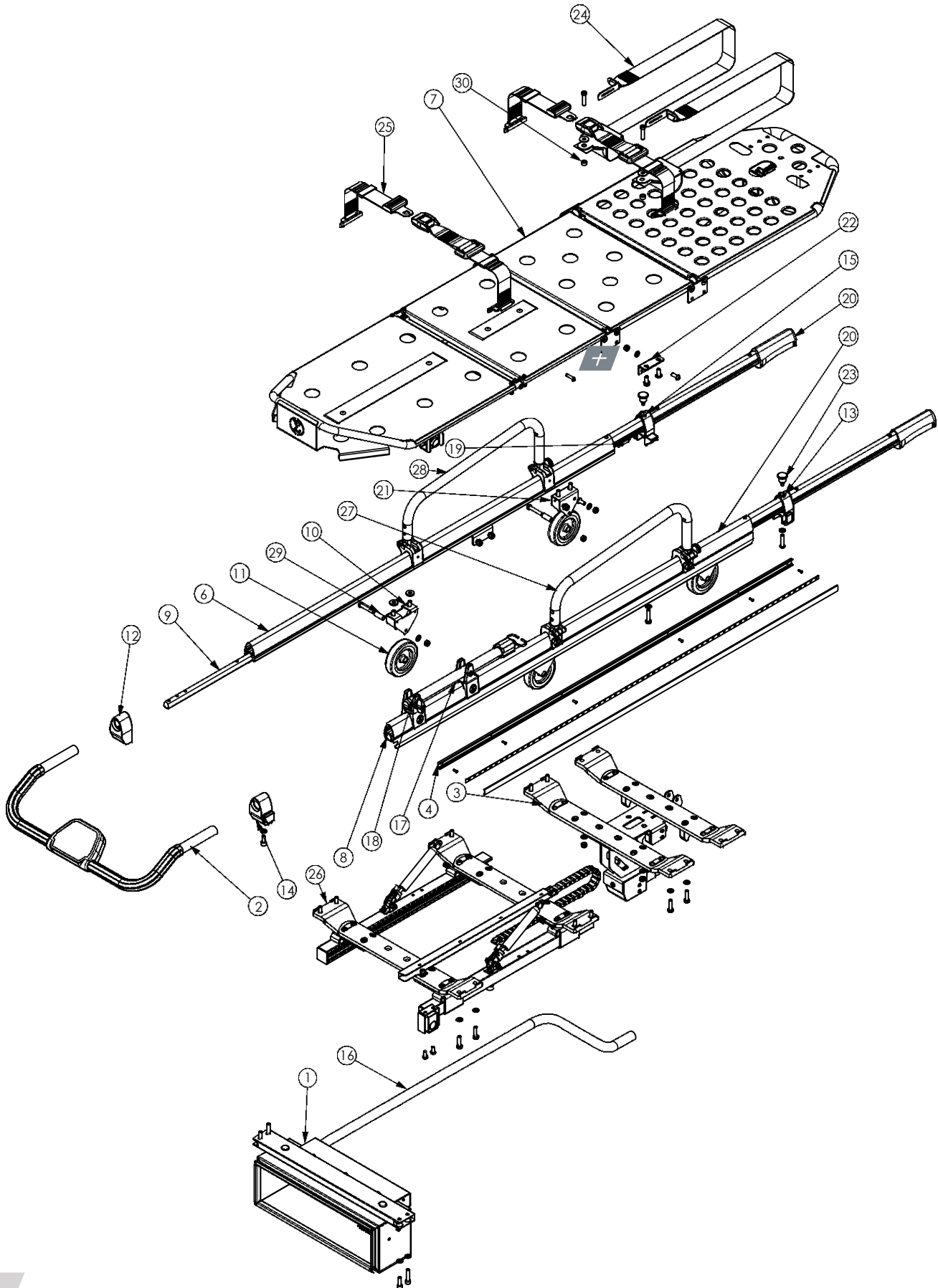

04 MOUNTING AND COMPONENTS

04.4 Bill of materials:

UPPER ENSAMBLE

PC-750

ELEMENT Nº	CODE - DESCRIPTION	QUANTITY
1	PC7500-12000A - Conjunt compartiment bateries V2	1
2	PC7500-09000 - Conjunt quadre de mandos	1
3	PC7500-17000 - Conjunt capçal de carrega camilla	1
4	PC7500-29000 - Conjunt LED LUZ NEGRA PC-750	2
5	PC7500-02012 - Per l superior alumini dret	1
6	PC7500-02022 - Per l superior alumini esquerra	1
7	PC7500-27000 - Conjunt llitera gas camilla electrica PC-750	1
8	PC7500-02070 - Femella subjeccio per l alumini dret	1
9	PC7500-02080 - Femella subjeccio per l alumini esquerra	1
10	PC7500-02092 - Suport roda conjunt superior camilla	2
11	CD-RUEDA-100 - roda 100x24	4
12	PC7500-02122 - Terminal per l superior esquerra	1
13	PC7500-02132 - Terminal per l capçal retractil dret	1
14	PC7500-02142 - Terminal per l superior dret	1
15	PC7500-02152 - Terminal per l capçal retractil esquerra	1
16	PC7500-18150 - Passacables endoll de carga llarg 140cm	1
17	PC6170-03500 - Suport barana portasueros universal	1
18	PC6170-03470 - Conjunt portasuero universal	1
19	GN-611-M10-8-L - Posicionador de muelle M10	2
20	PC7500-32000 - Conjunto maneta extensible PC-750 (REPUESTO)	2
21	PC7500-27092 - Suport roda davantera superior camilla	2
22	PC7500-27082 - Angle suport pletina llitera	2
23	GN 822-7-B-ST - Pom posicionador sense bloqueig	2
24	PC7500-01130 - Conjunt cinturo retractil 10G Arnes	1
25	PC6500-04110 - Conjunt cinturons 10G Peus	1
26	PC7500-01350 - CONJUNT TIRANTS POSTERIORES	1
27	PC7500-35000 - Conjunt baraneta abatible dreta	1
28	PC7500-34000 - Conjunt baraneta abatible esquerra	1
29	COMP00867 - Casquell rodes 12x30	4
30	105-4-CATUB - CASQUILLO 14x7x3 CINCADO	2

04 MOUNTING AND COMPONENTS

04.5 Exploded view

UPPER ENSAMBLE

PC-751

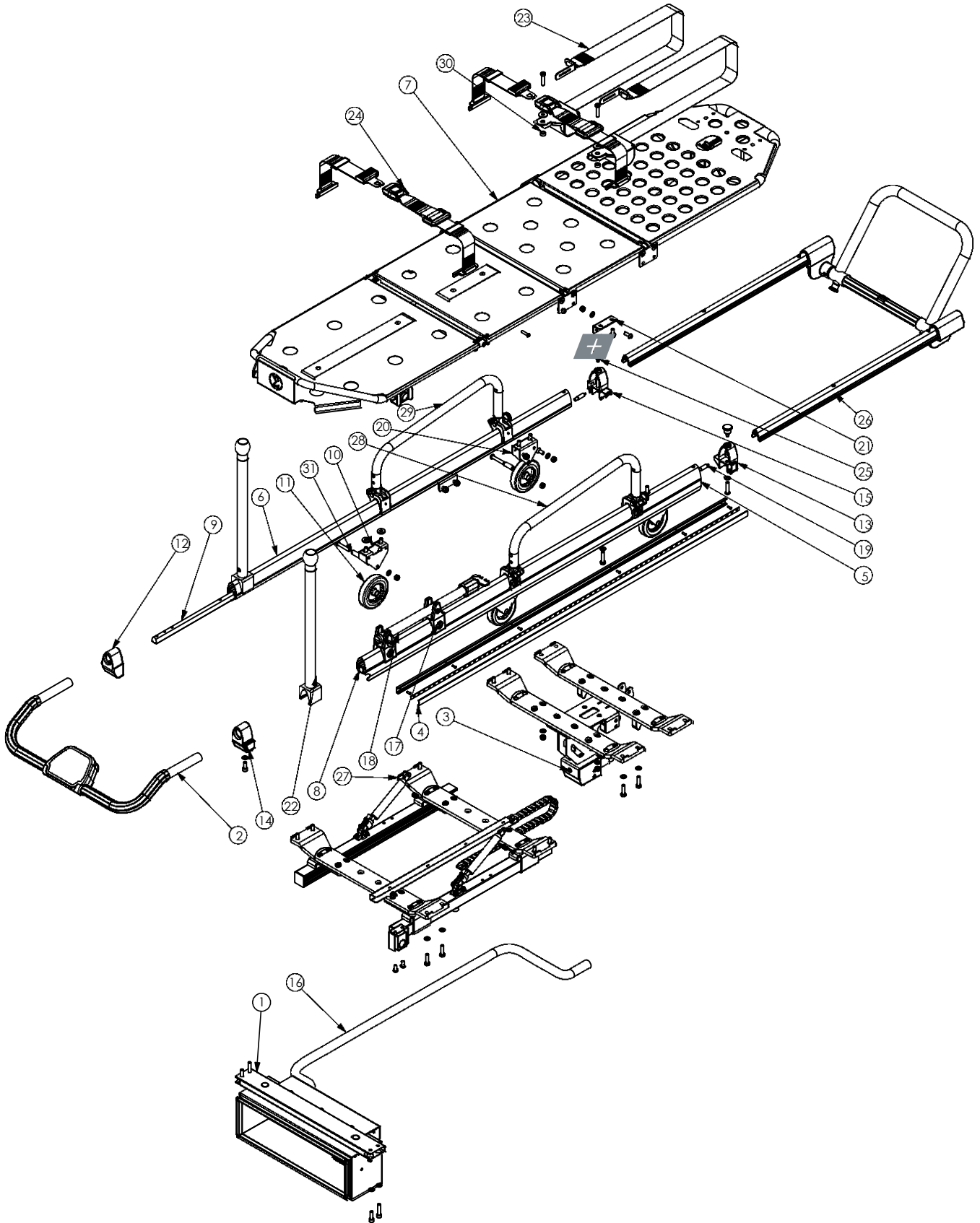

04 MOUNTING AND COMPONENTS

04.5 Bill of materials: UPPER ENSAMBLE PC-751

ELEMENT Nº	CODE - DESCRIPTION	QUANTITY
1	PC7500-12000A - Conjunt compartiment bateries V2	1
2	PC7500-09000 - Conjunt cuadro de mandos	1
3	PC7500-17000 - Conjunt capçal de carrega camilla	1
4	PC7500-29000 - Conjunt LED LUZ NEGRA PC-750	2
5	PC7500-02012 - Per l superior alumini dret	1
6	PC7500-02022 - Per l superior alumini esquerra	1
7	PC7500-27000 - Conjunt llitera gas camilla electrica PC-750	1
8	PC7500-02070 - Femella subjeccio per l alumini dret	1
9	PC7500-02080 - Femella subjeccio per l alumini esquerra	1
10	PC7500-02092 - Suport roda conjunt superior camilla	2
11	CD-RUEDA-100 - roda 100x24 	4
12	PC7500-02122 - Terminal per l superior esquerra	1
13	PC7500-02132 - Terminal per l capçal retractil dret	1
14	PC7500-02142 - Terminal per l superior dret	1
15	PC7500-02152 - Terminal per l capçal retractil esquerra	1
16	PC7500-18150 - Passacables endoll de carga llarg 140cm	1
17	PC6170-03500 - Suport barana portasueros universal	1
18	PC6170-03470 - Conjunt portasuero universal	1
19	GN.611-M10-8-L - Posicionador de muelle M10	2
20	PC7500-27092 - Suport roda davantera superior camilla	2
21	PC7500-27082 - Angle suport pletina llitera	2
22	PA7300-01000 - Conjunt empunyadura davantera	2
23	PC7500-01130 - Conjunt cinturo retractil 10G Arnes	1
24	PC6500-04110 - Conjunt cinturons 10G Peus	1
25	GN-822-7-B-ST - Pom posicionador sense bloqueig	2
26	PC7510-10000 - Conjunt marc capçal extensible (inglaterra)	1
27	PC7500-01350 - CONJUNT TIRANTS POSTERIORIS	1
28	PC7500-35000 - Conjunt baraneta abatible dreta	1
29	PC7500-34000 - Conjunt baraneta abatible esquerra	1
30	105-4-CATUB - CASQUILLO 14x7x3 CINCADO	2
31	COMP00867 - Casquell rodes 12x30	4

04 MOUNTING AND COMPONENTS

04.6 Exploded view

UPPER ENSAMBLE

PC-755

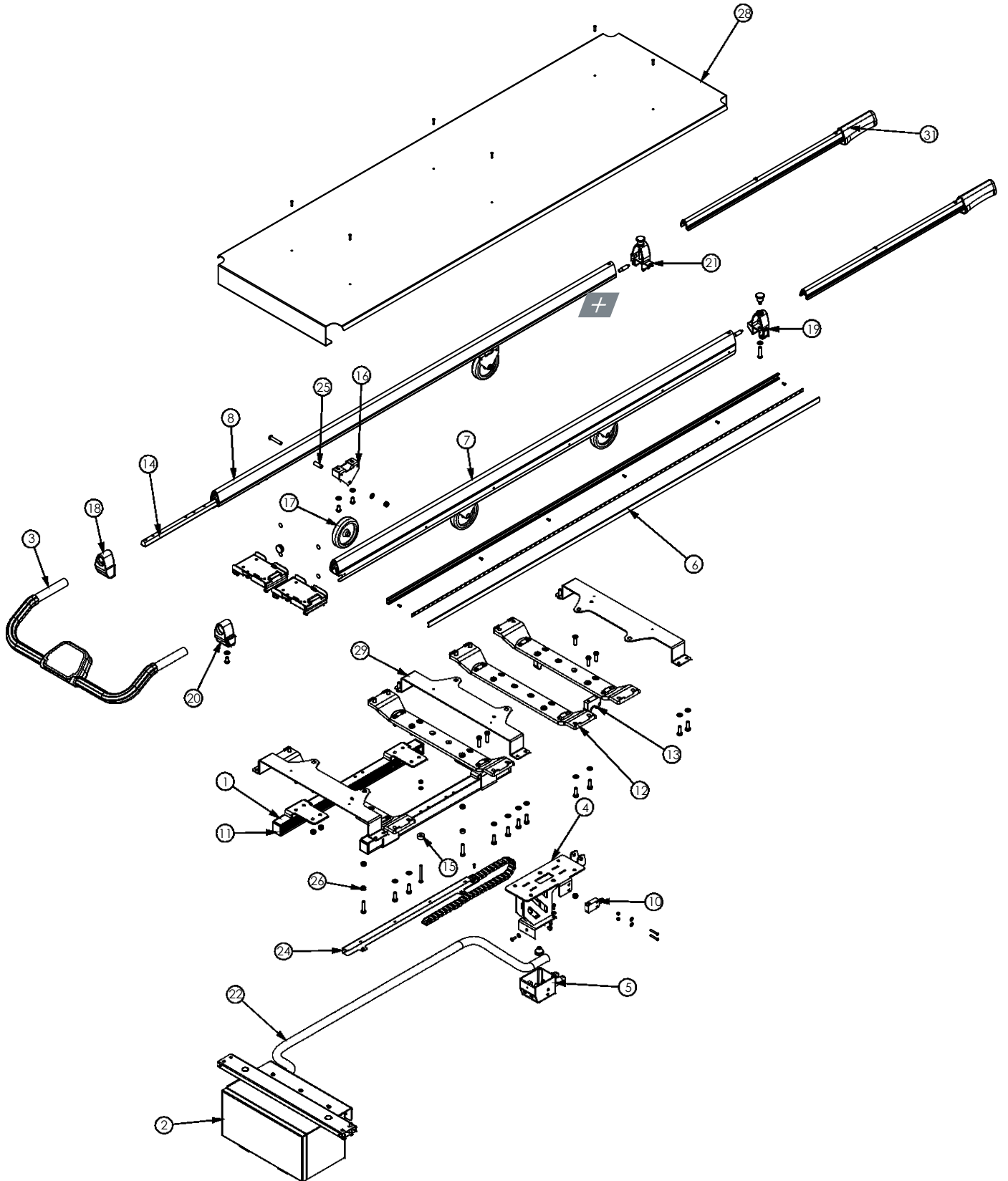

04 MOUNTING AND COMPONENTS

04.7 Exploded view

STRETCHER BED

PC-750 / PC-751

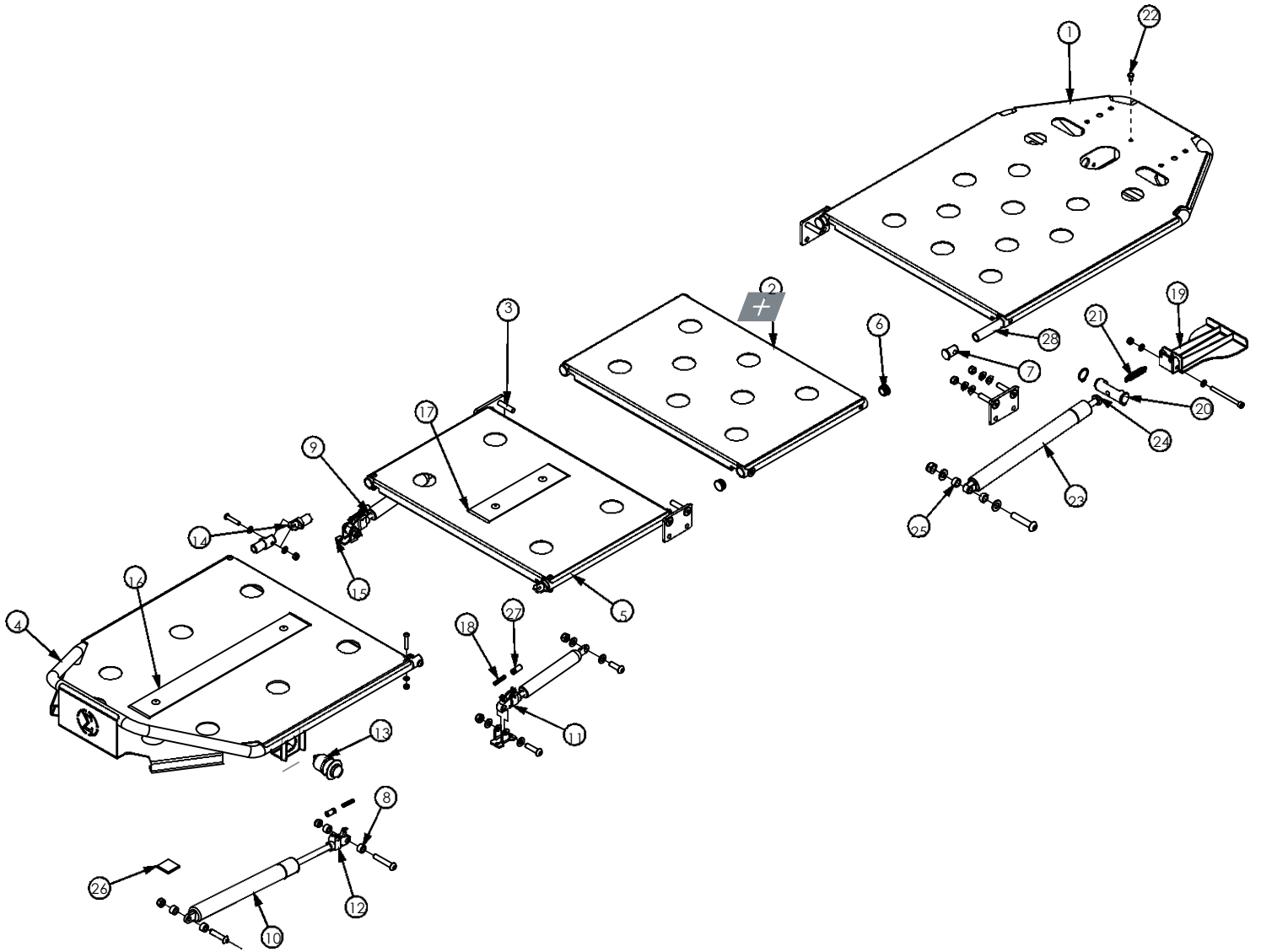

04 MOUNTING AND COMPONENTS

04.8 Exploded view

BATTERIES CABINET

PC-750 / PC-751 / PC-755

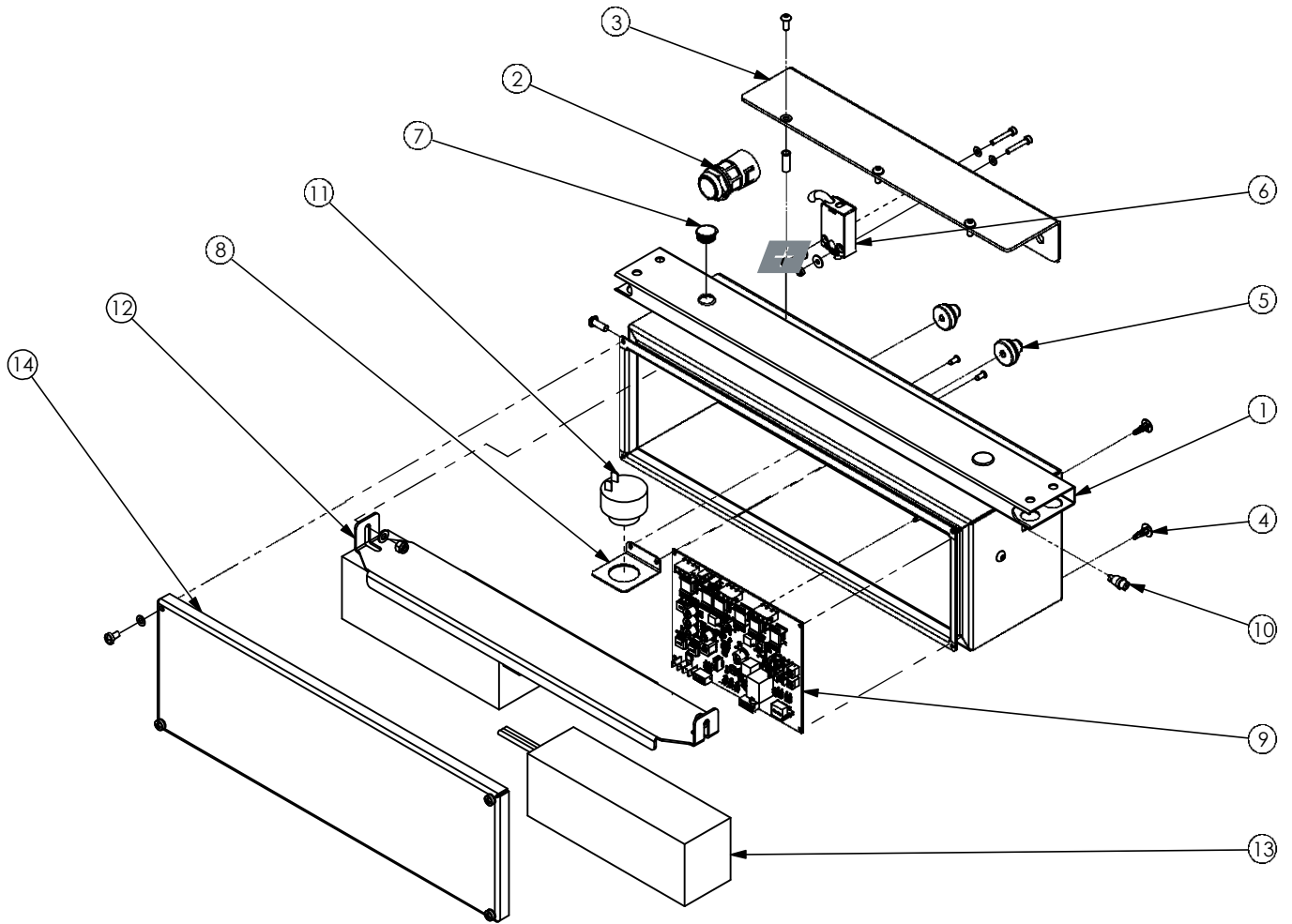

04 MOUNTING AND COMPONENTS

04.9.1 Exploded view

RIGHT HANDRAIL

PC-750 / PC-751

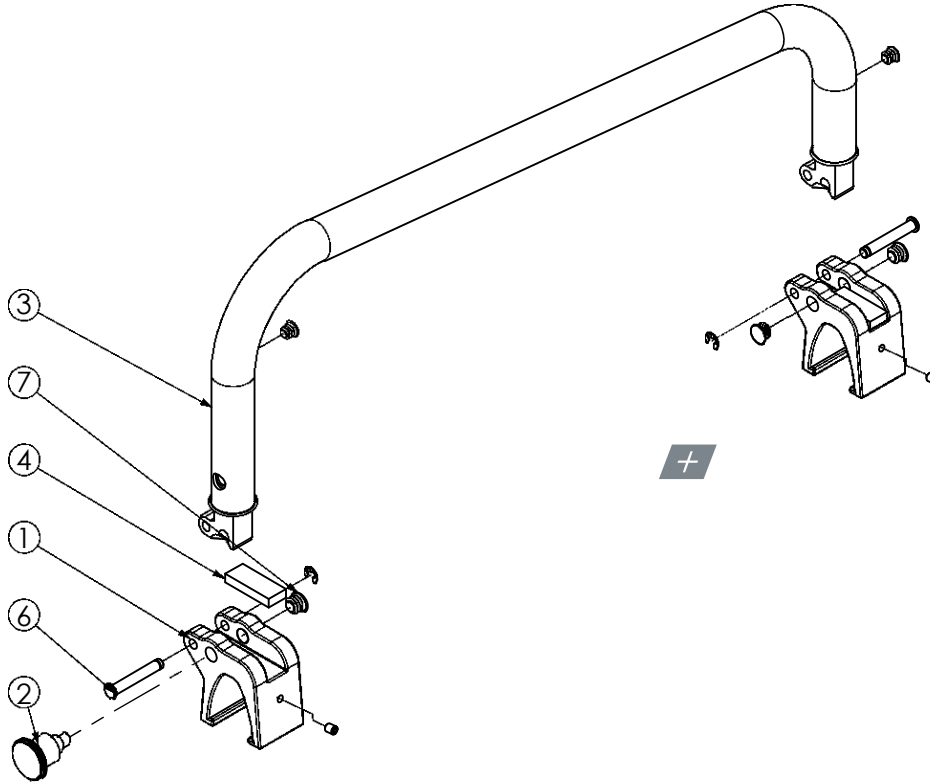

04.9.2 Exploded view

LEFT HANDRAIL

PC-750 / PC-751

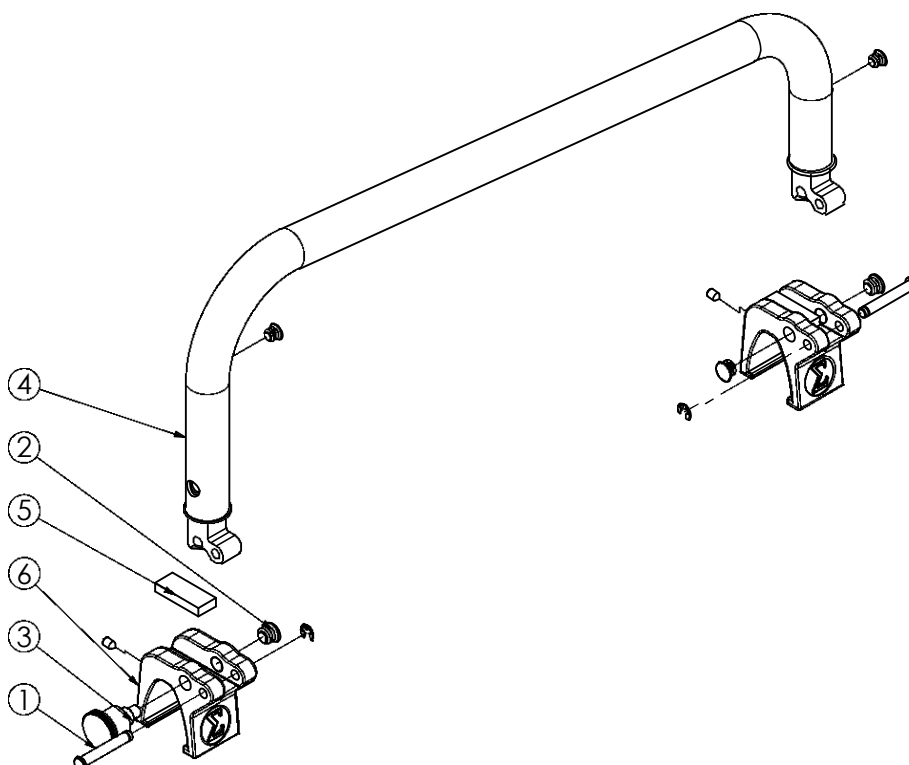

04 MOUNTING AND COMPONENTS

04.9.1 Bill of materials:

RIGHT HANDRAIL

PC-750 / PC-751

ELEMENT Nº	CODE - DESCRIPTION	QUANTITY
1	GN 822-7-B-ST - Pom posicionador sense bloqueig	1
2	PC7500-35102 - Subconjunt baraneta dreta amb suport	1
3	1330000411 - Junta autoadhesiva 14x6	2
4	PC7500-34030 - suport baraneta abatible	2
5	TAP-PLASTØ10 - TAPON PLASTICO Ø10 - Mod. 17-10	2
6	PC7500-34040 -PERNO CON RANURA MECANIZADO 6X41 CINCADO	2
7	TAP-PLASTØ12 - TAPON PLASTICO Ø12 - Mod. 17-12	3



04.9.2 Bill of materials:

LEFT HANDRAIL

PC-750 / PC-751

ELEMENT Nº	CODE - DESCRIPTION	QUANTITY
1	PC7500-34040 -PERNO CON RANURA MECANIZADO 6X41 CINCADO	2
2	TAP-PLASTØ12 - TAPON PLASTICO Ø12 - Mod. 17-12	3
3	GN 822-7-B-ST - Pom posicionador sense bloqueig	1
4	PC7500-34102 - Subconjunt baraneta esquerra amb suport	1
5	1330000411 - Junta autoadhesiva 14x6	2
6	PC7500-34030 - suport baraneta abatible	2
7	TAP-PLASTØ10 - TAPON PLASTICO Ø10 - Mod. 17-10	2

04 MOUNTING AND COMPONENTS

04.10 Exploded view

TELESCOPIC FRAME

PC-751

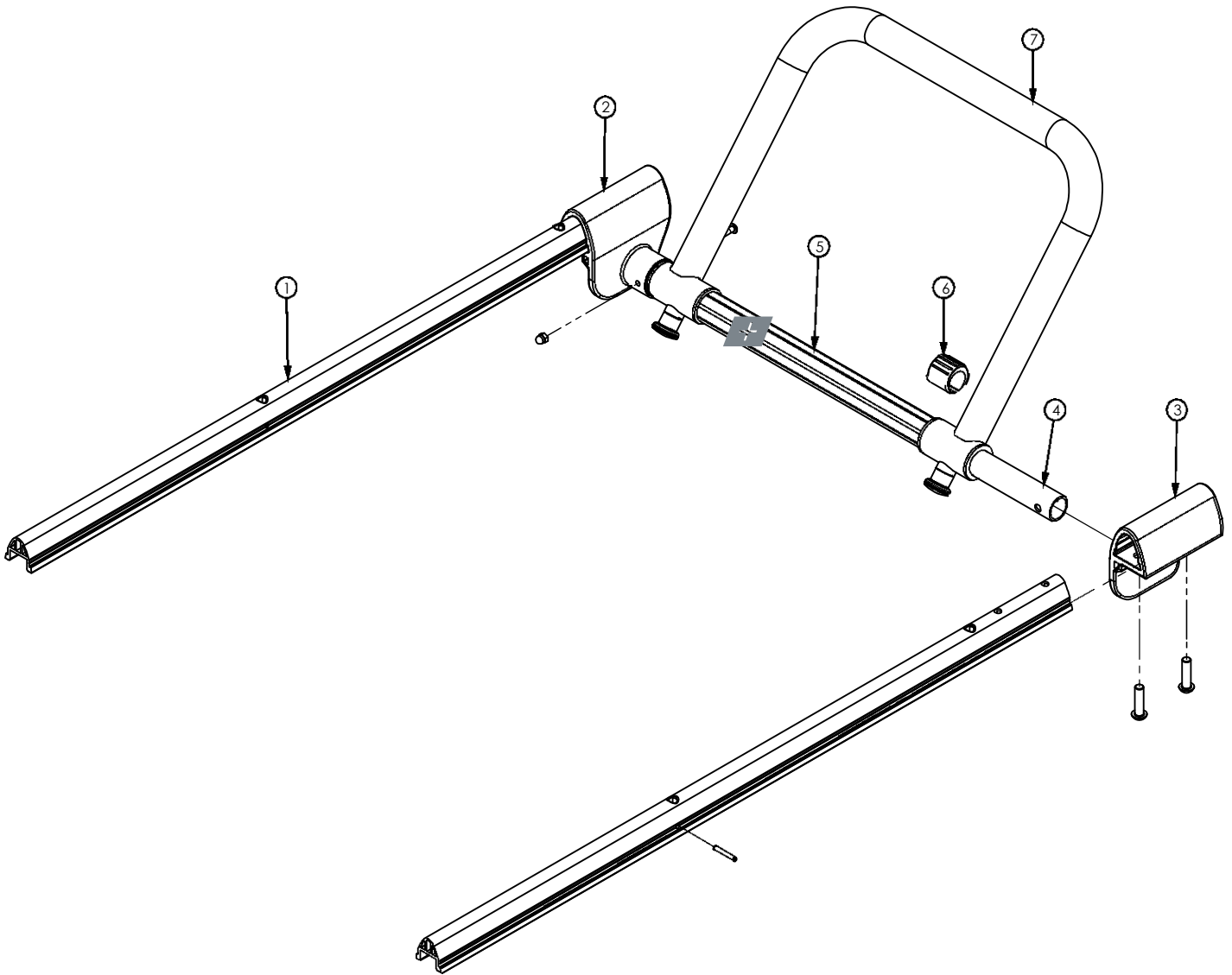

04.11 Exploded view

REAR STRUCTURE

PC-750 / PC-751

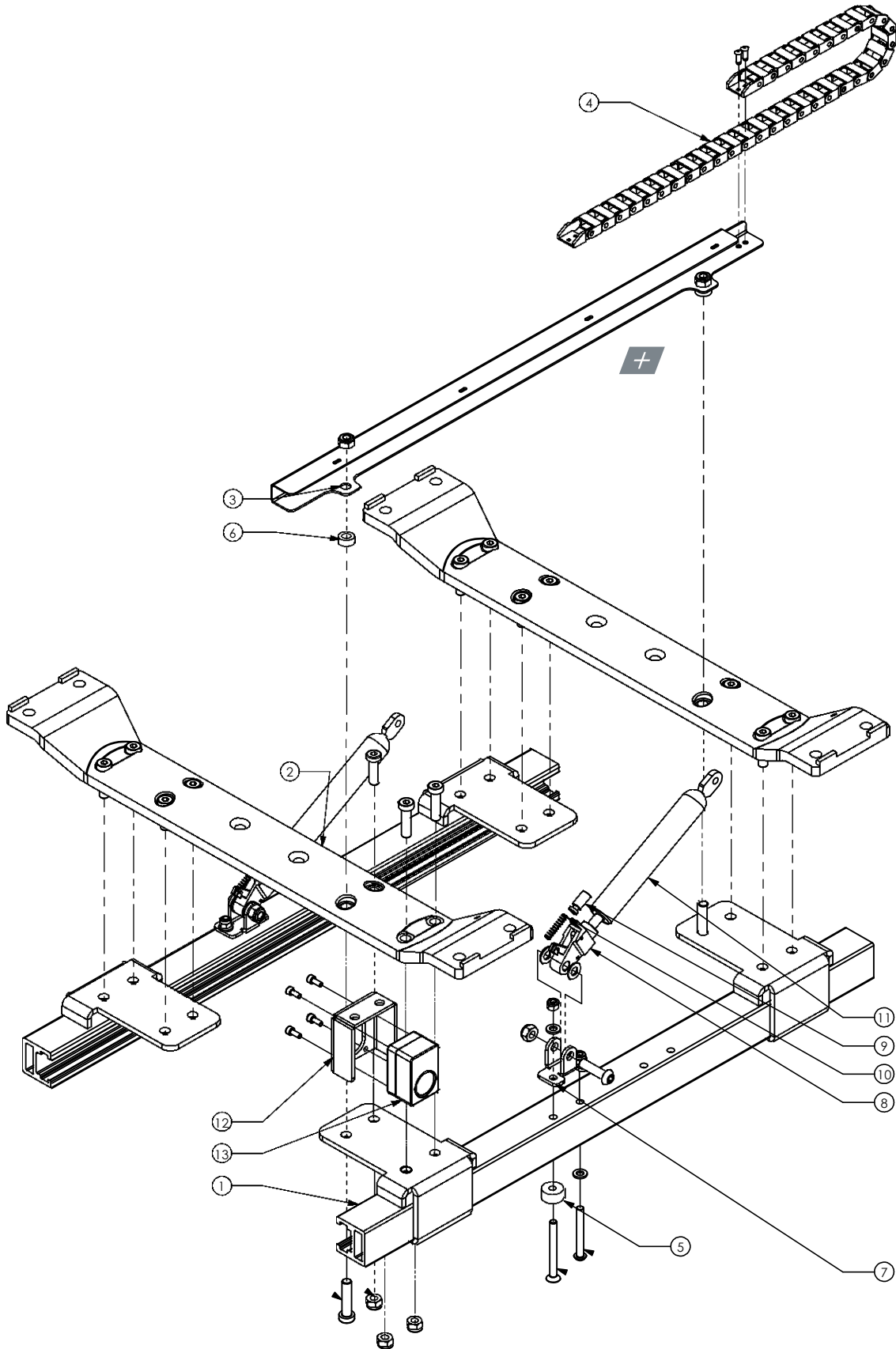

04.12 Exploded view

CHARGING SYSTEM

PC-750 / PC-751

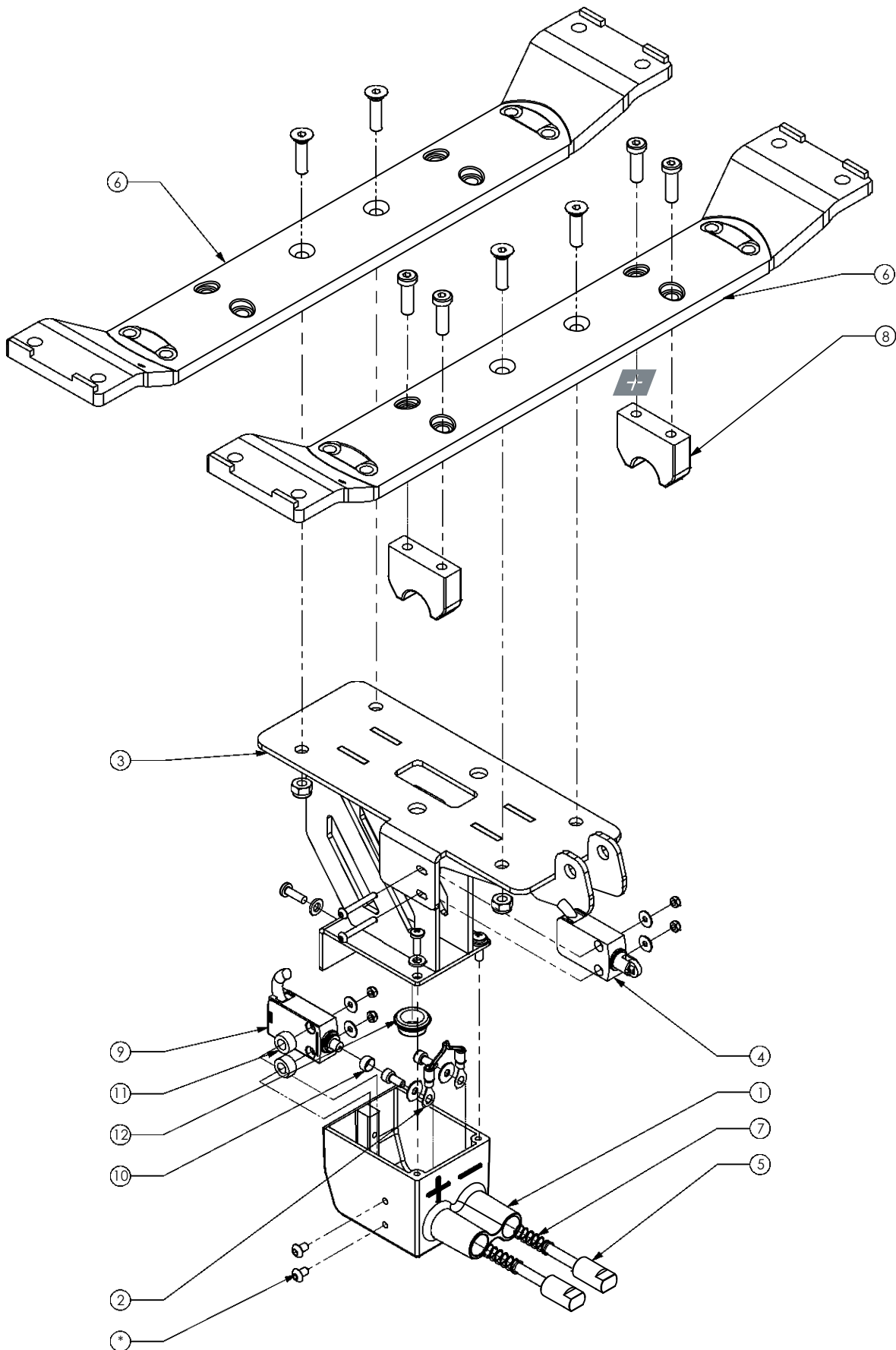



04 MOUNTING AND COMPONENTS

04.13 Main exploded view

SUPPORT

PB-720 / PB-725

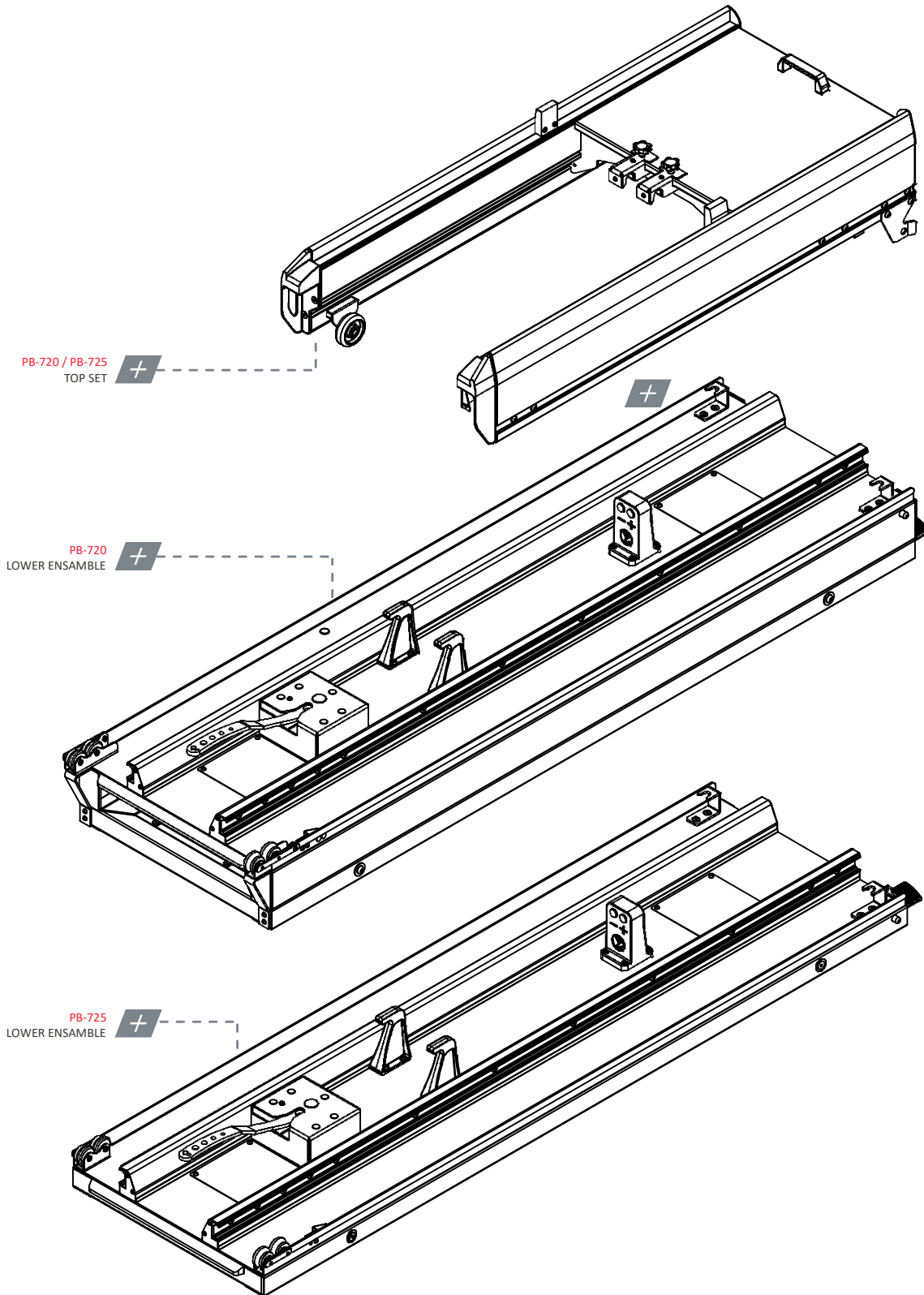

When ordering spare parts, please indicate the **color** of the support for which it is intended

04 MOUNTING AND COMPONENTS

04.14 Exploded view

REMOVABLE RAIL

PB-720 / PB-725

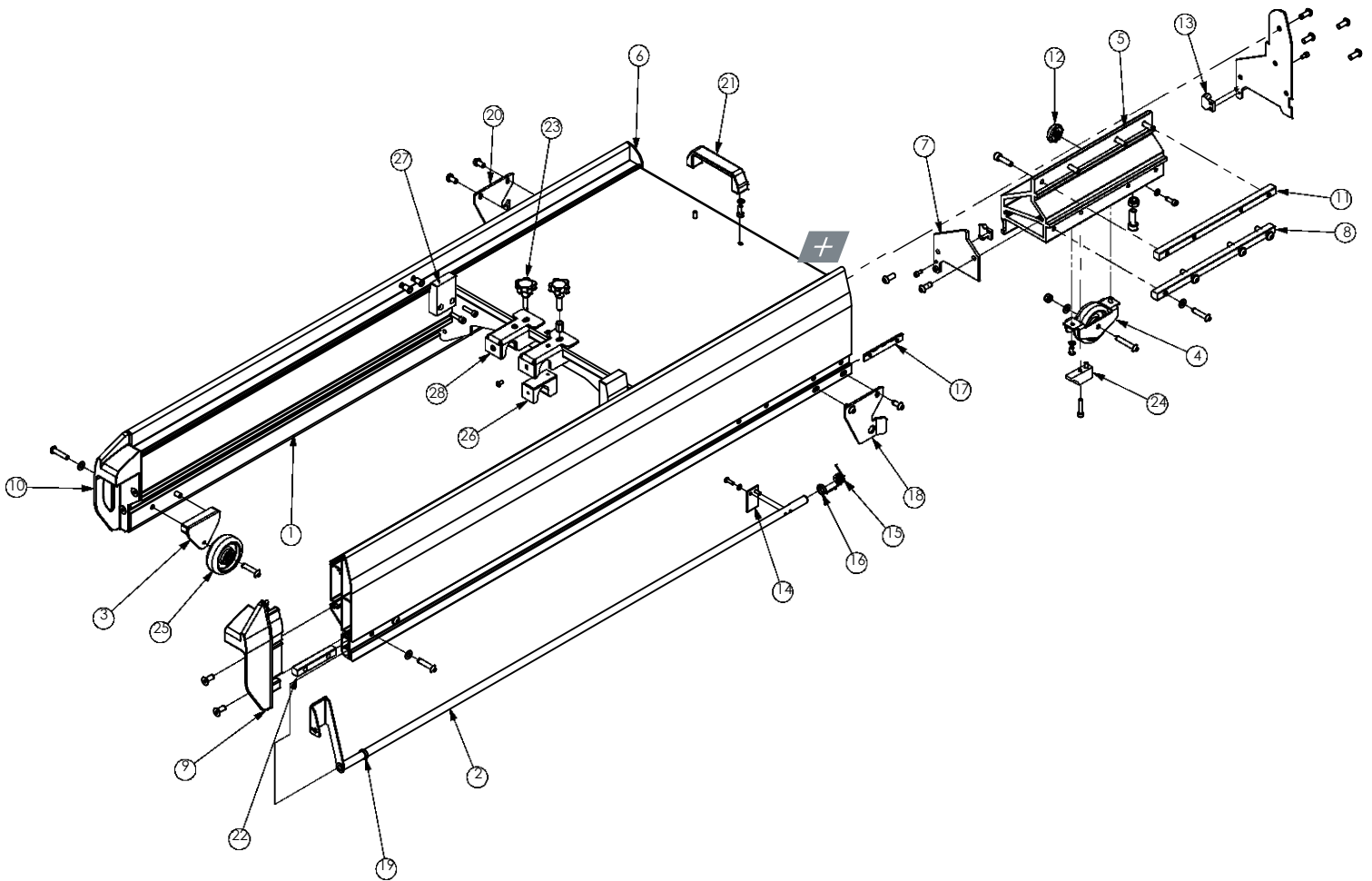

04 MOUNTING AND COMPONENTS

04.15 Exploded view

FIX RAIL

PB-720

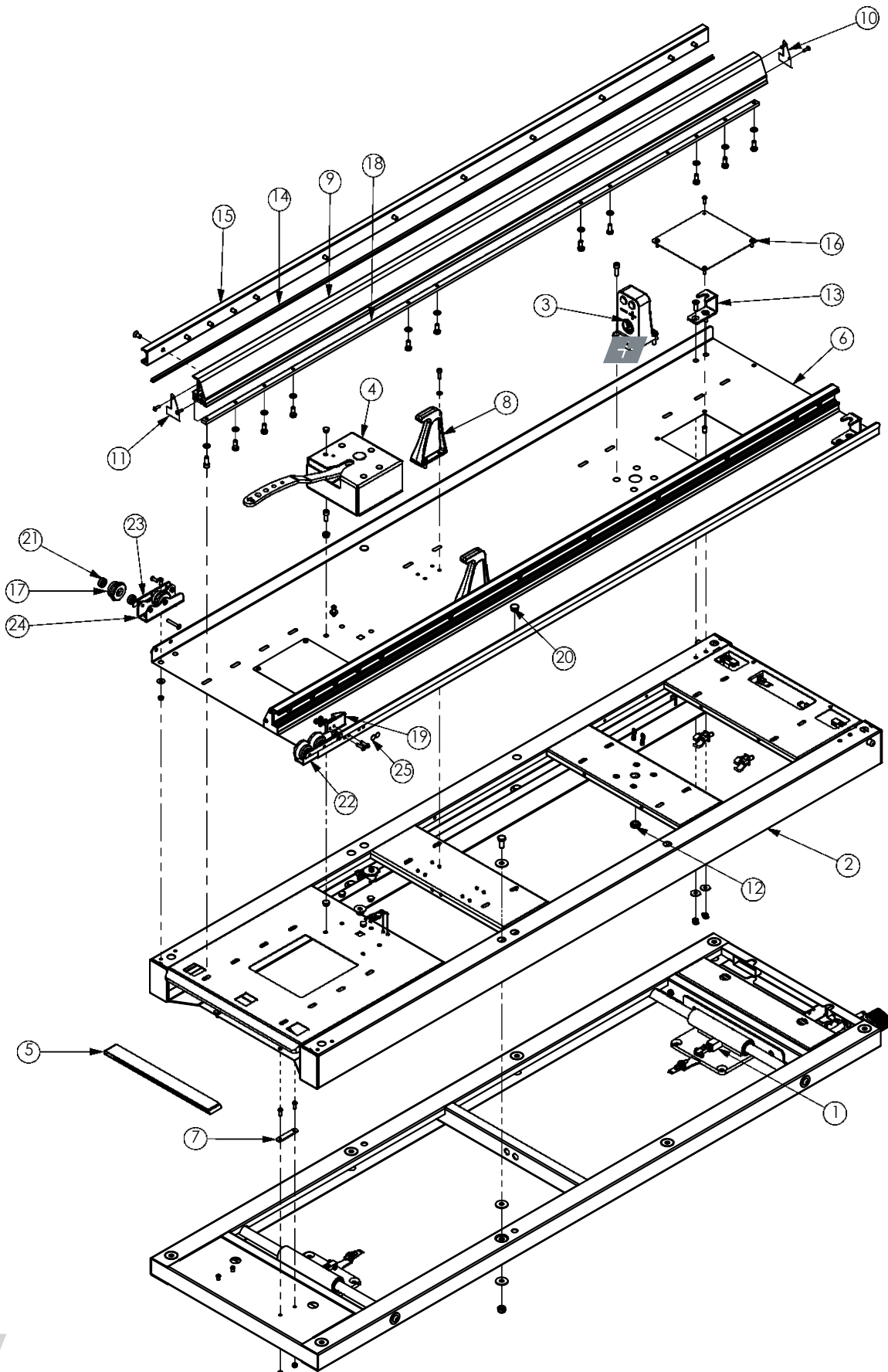

04 MOUNTING AND COMPONENTS

04.16 Exploded view

PLATFORM

PB-720

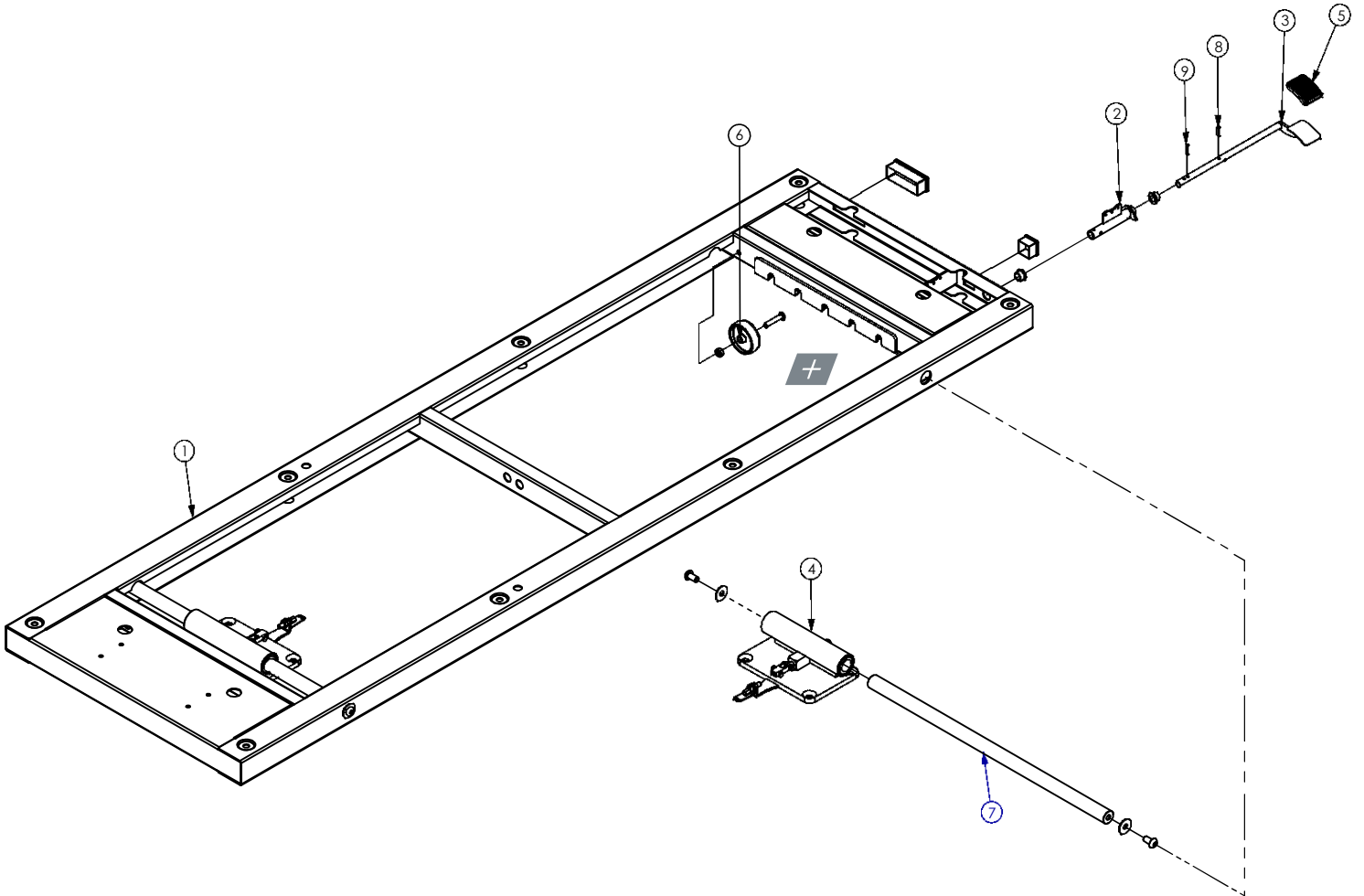

04 MOUNTING AND COMPONENTS

04.17 Exploded view

SUPPLEMENT

PB-720

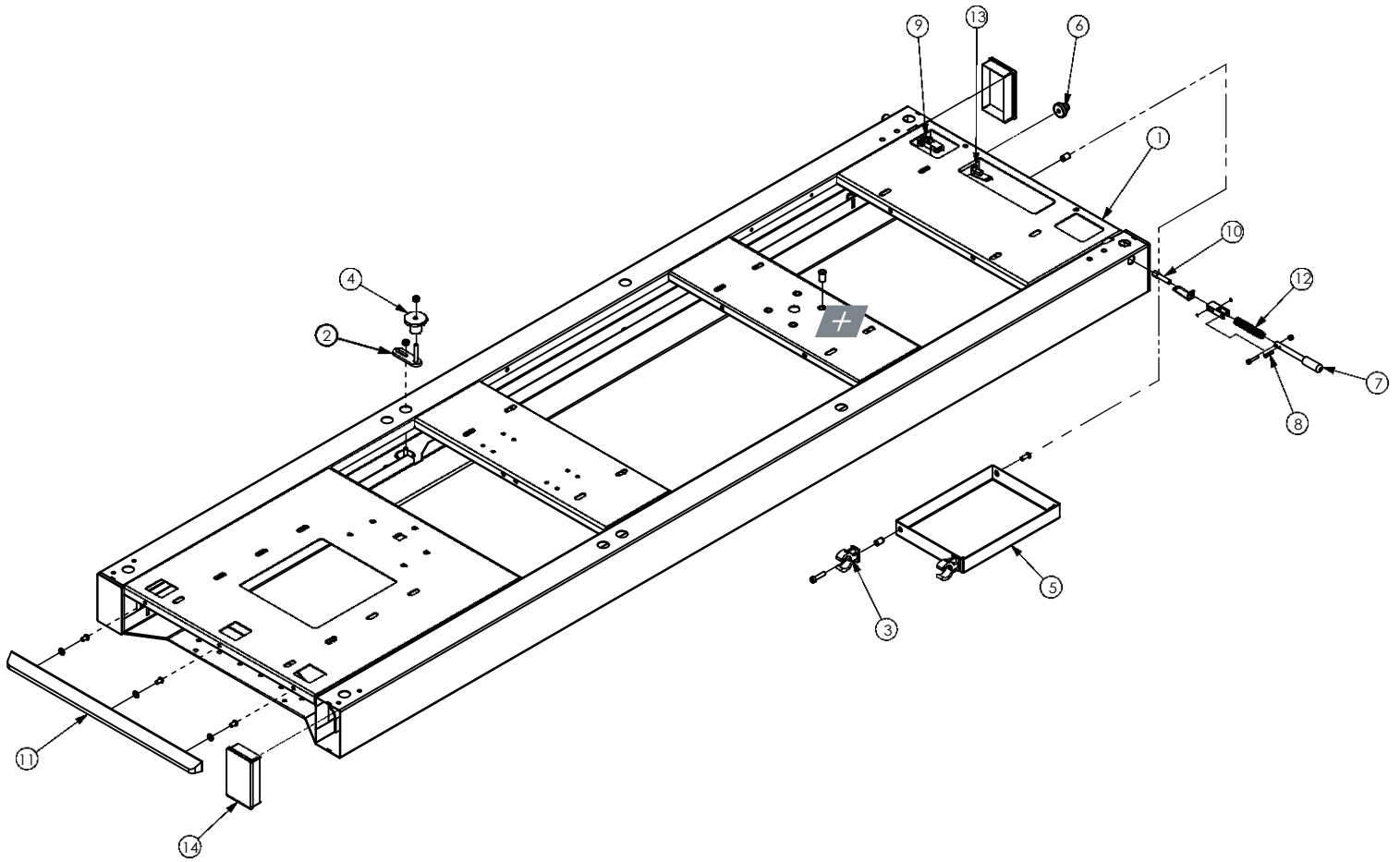

04 MOUNTING AND COMPONENTS

04.18 Exploded view

FIX FAIL

PB-725

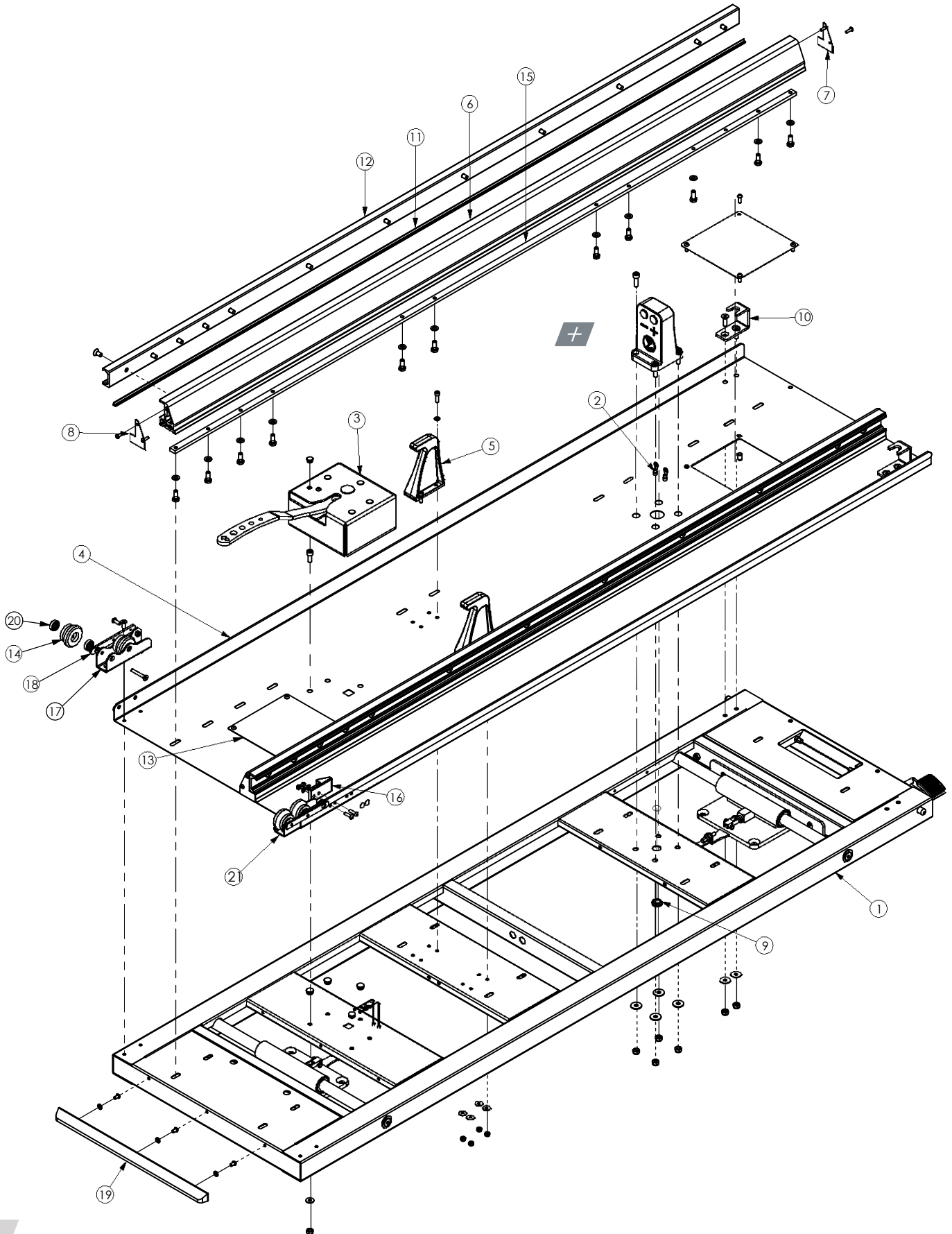

04 MOUNTING AND COMPONENTS

04.19 Exploded view

PLATFORM

PB-725

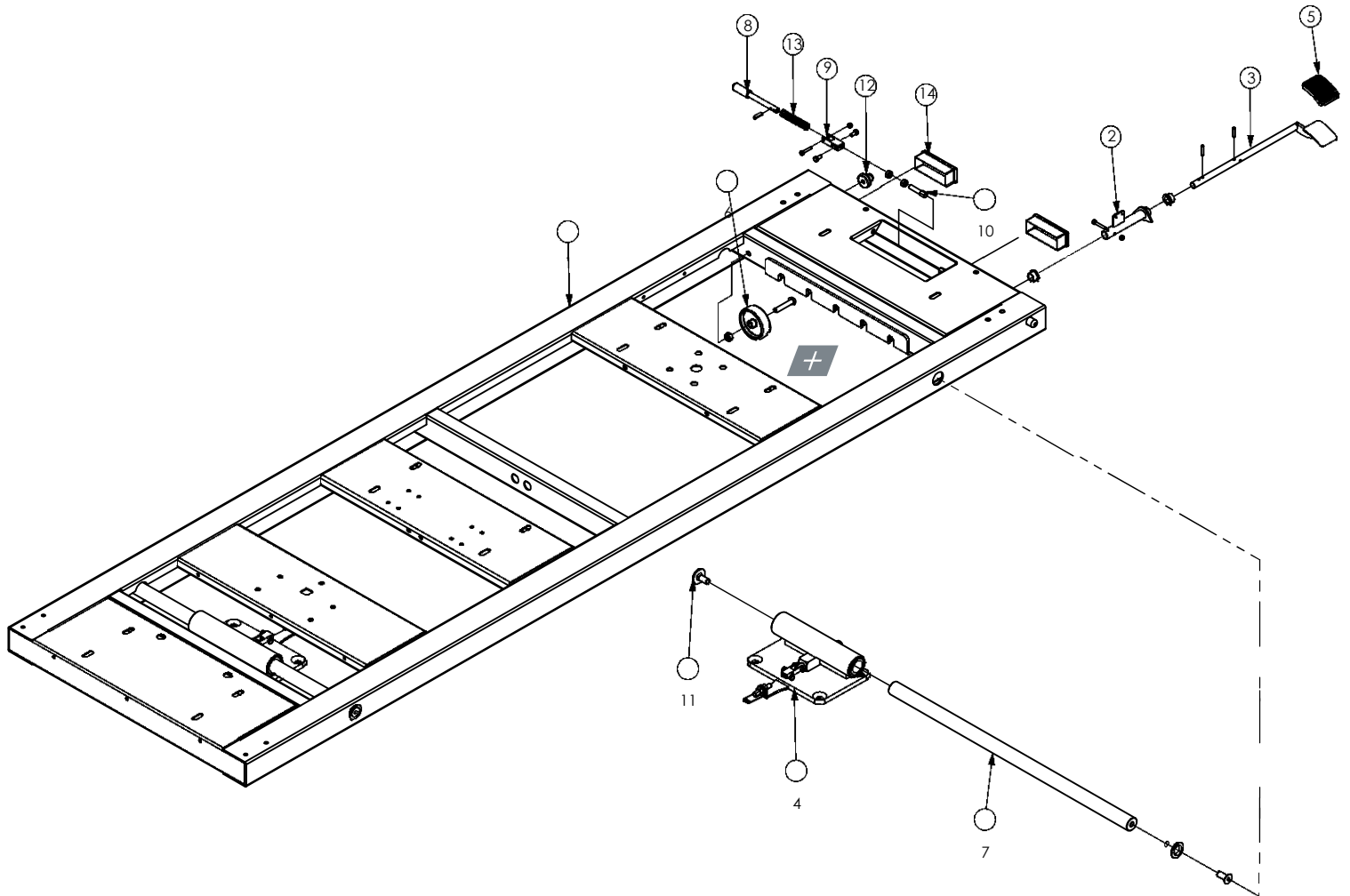

04 MOUNTING AND COMPONENTS

04.20 Exploded view

SCREWED PLATE

PB-720 / PB-725

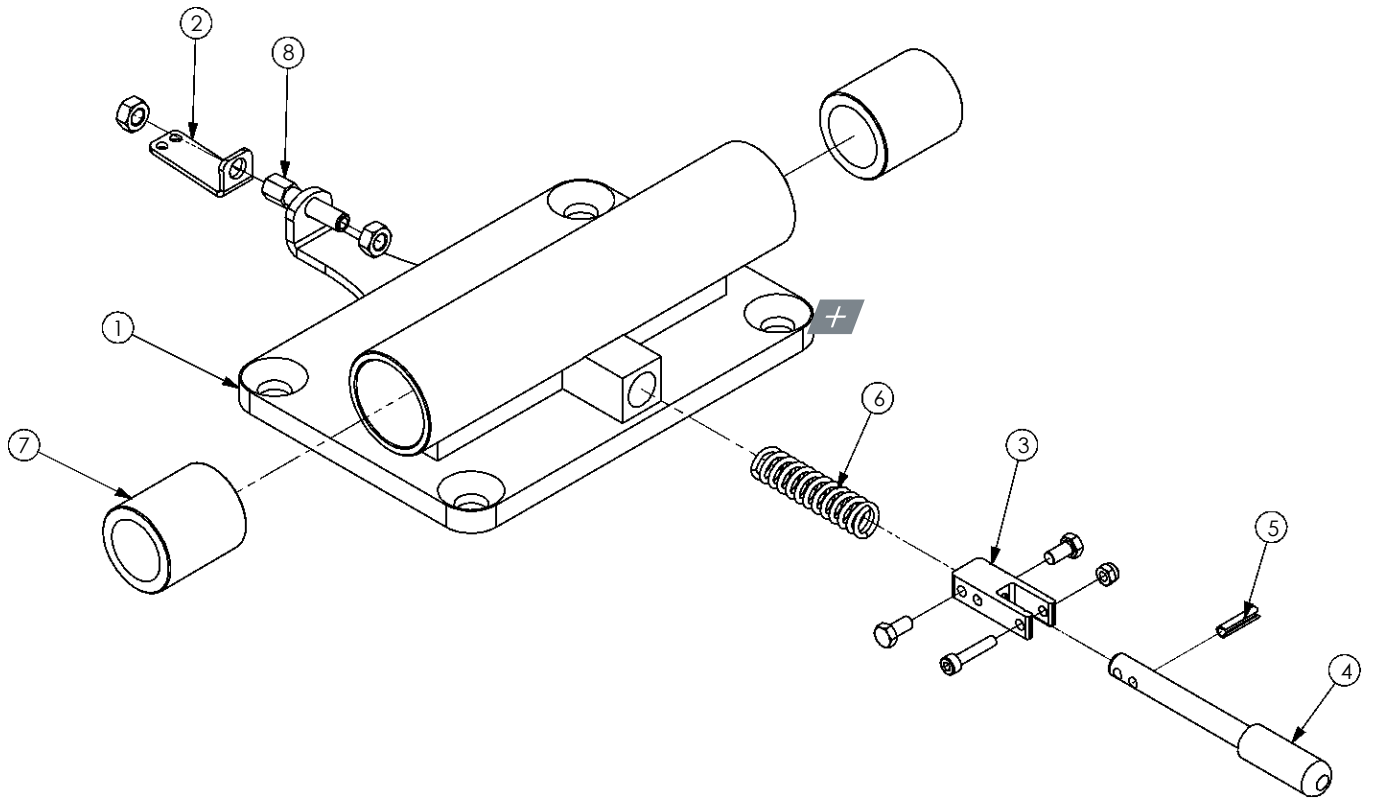

04 MOUNTING AND COMPONENTS

04.21 Exploded view

THIRD POINT LOCK

PB-720 / PB-725

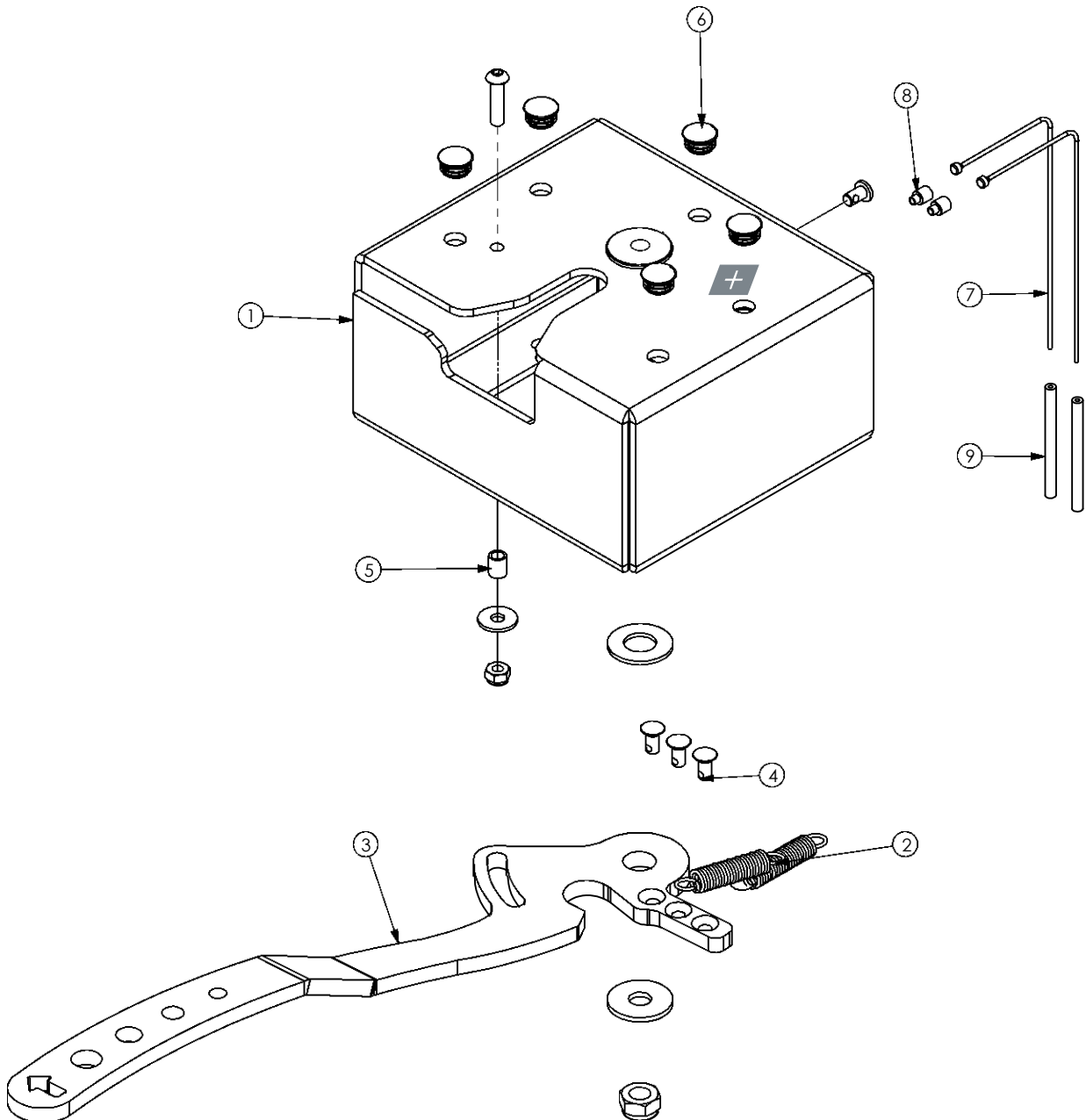

05 WIRING DIAGRAM

05.2 Electrical wiring diagram

Wiring lines

- A. Power input line (12V dc)
- B. Final microswitch line load terminal C.
- C. Final microswitch line of superior run
- D. Electro-hydraulic group connection line (24V dc)
- E. Final microswitch line of lower run
- F. Supply line left LED lights (12V dc)
- G. Supply line right LED lights (12V dc)
- H. Communication line of control panel
- I. Supply line buzzer (12v dc)
- J. External charger connector connection line (12V dc)
- K. Load line between support and ambulance (12V dc)

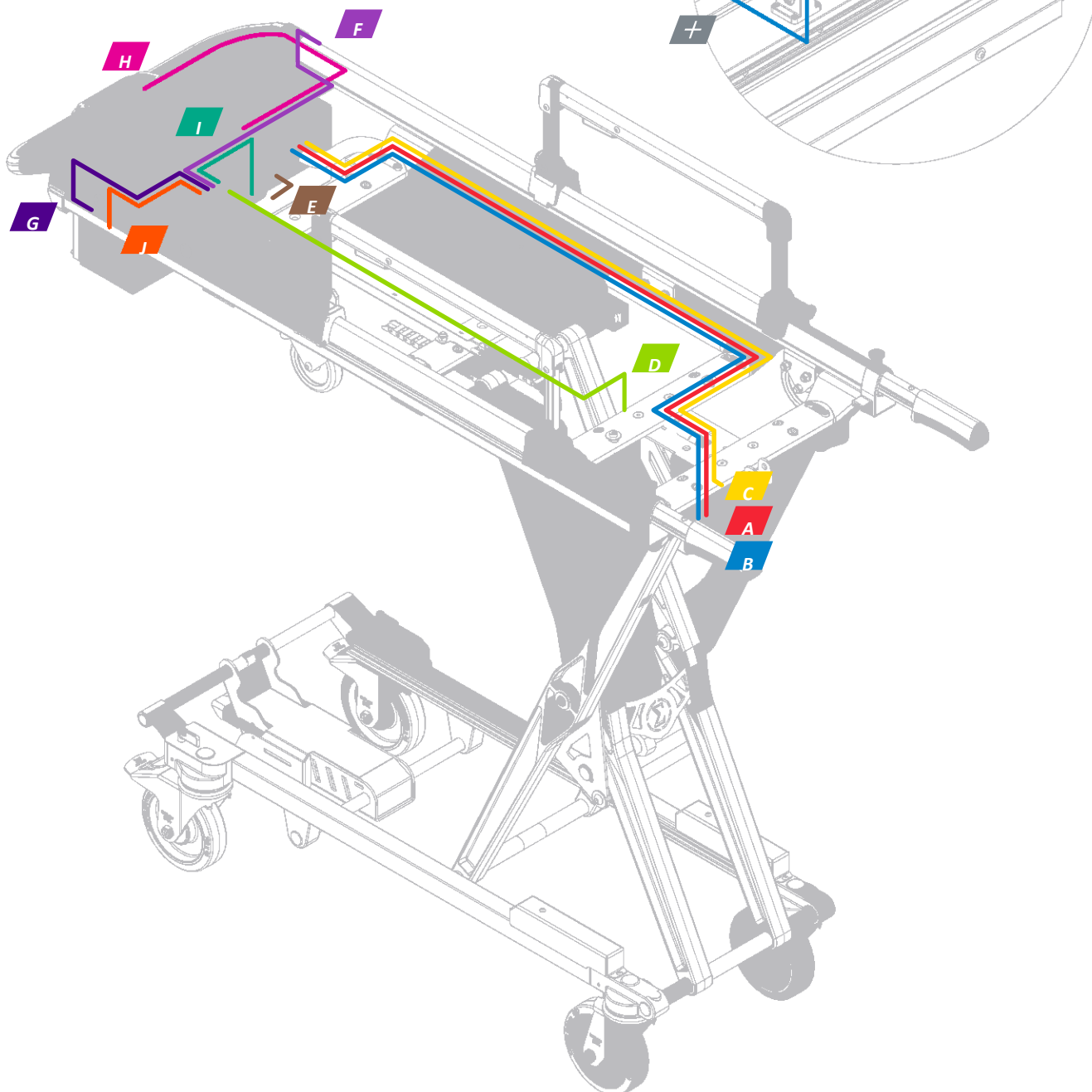



06 GENERAL MAINTENANCE

CLEANING

Keeping the equipment cleaned is essential to ensure a good use and durability of the set. It is necessary to make a periodical thorough cleaning, especially in areas exposed to dirt that could suffer damages, such as gears, connectors, switches, etc. Do not use high-pressure cleaning, they can damage the electrical elements.

CONTROLS AND SELECTORS

Due to a heavy and continued use of the moving parts, such as controls and selectors, check them periodically for a proper functioning. There may be failures on micro-switches and cabling; examine the fixations and electric or mechanical connections that could exist.

GREASE

Generally, every moving part should be greased. Our products leave the factory completely greased and lubricated, however, it is possible that with the time and usage of the product the elements degrease, either by loss of lubrication or by dirt. Clean and grase periodically the affected zones according to the manufacturer's specifications.

Verify that there are no loose, worn, or missing parts. Examine periodically every moving element to ensure that they are all tighten.

Do not grease the platform guide because of its sliding dry system.

WARNING: Do not lubricate the support once connected to the electricity network.

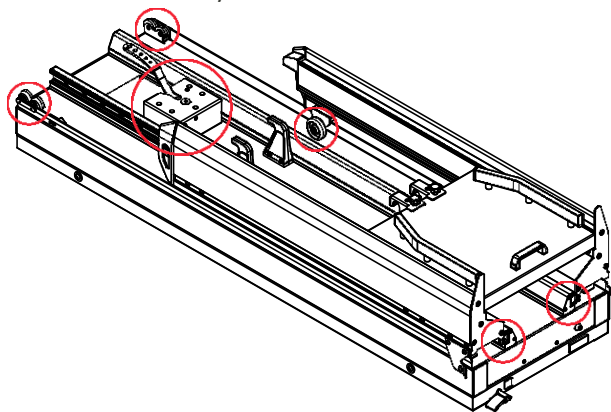

WEAR AREAS

Regularly examining the system's components to check if they are wearing out is a preventive measure that can reduce breakdowns. Verify possible lubricate leaks, grooves or bearings in poor condition.

MECHANICAL FIXING

Generally we call mechanical fixing to the components that are used to attach joint products, mainly screws and derivatives.

In some conditions of use, due to vibrations or impacts, many elements could lose their tightening torque or hold properties.

Periodically examine that no elements are unleashed, especially in the moving parts of the set. Take into account and always respect the recommended tightening torques.

REPLACEMENT OF COMPONENTS

This instruction manual does not include procedures for every part. The service staff typically substitutes cables, commutators and certain mechanical parts without any step by procedure.

The qualified service personnel must contact our sales department for information about ordering pieces and its installation.

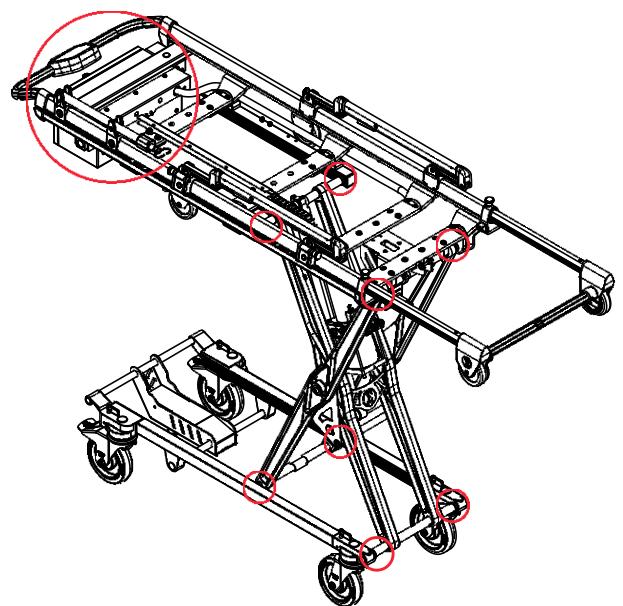

Make sure to keep these areas free of water and moisture. Take special care not to get them wet when washing the set.

07 LEGAL NOTICES

This document may contain technical inaccuracies or typographical errors.

Changes are periodically added to the information herein; these changes will be incorporated in new editions of the publication.

Promeba, S.L. reserves the right to make any modification or improvement in the products described in this publication if it is appropriate.

Promeba, S.L. may have patents or patent applications which address themes described in this document. The possession of this document does not entitle no license to these patents.

The information contained in this document does not affect or change the specifications or product specifications or warranties of **Promeba, S.L.**

No part of this document shall operate as express or implied license or compensation under the intellectual property rights of **Promeba, S.L.** or third party.

All the information contained in this document has been obtained in specific environments and it is presented as an illustration. The results obtained in other operating environments may vary.

Promeba, S.L. can use or distribute the information that the client provides in whatever way they see fit, without incurring any obligation with the client.

08 PRODUCT WARRANTY

Promeba, S.L. warrants that their products have successfully passed all quality controls, both functional and material. The warranty period is 2 years from the date of purchase.

This warranty will only be granted when the original invoice or sales receipt (indicating the date of purchase, model and the distributor's name) is presented together with the defective product during the warranty period. **Promeba, S.L.** reserves the right to not offer the free warranty service if the indicated documents are not presented or if the information provided the consumer is false, incomplete or illegible.

1. This warranty shall not apply if the model's name or the serial number has been altered, removed, disappeared or is illegible.

*2. This warranty does not cover transportation costs or risks associated with the transport of product to and from **Promeba, S.L.***

3. This warranty does not cover any of the following cases:

a) Regular maintenance and repairation or replacement of parts from normal wear and tear.

b) Consumibles (components that may need periodic replacement during the product's life, such as non-chargeable batteries, bulbs, etc.)

c) Damages or defects resulting from the use, operation or improper treatment of the product and not caused by a normal use of it.

d) Damages arising from

i. Improper use, including:

- Treatment resulting in damages or physical changes, surface or appearance changes of the product.

- Installation, use or storage of the product in a manner inconsistent with the instructions described by **Promeba, S.L.**

- Product maintenance in a manner inconsistent with the inconsistent with the instructions of **Promeba, S.L.** for a proper maintenance.

- Installation or product use in a manner inconsistent with the technical or security standards of the country where it is used or installed.

ii. Use of components not supplied with the product or incorrect installation of accessory parts previously untested.

iii. States or defects system in which the product is incorporated with the exception of other products of **Promeba, S.L.** designed for its use with the product.

iv. Product use with accessories, peripherals units and other products of a type, condition or standard not established by **Promeba, S.L.**

v. The manufacturer or distributor shall be solely responsible for determining the sending of parts for its reparation or the replacement of the product in its entirety. In no circumstance shall operators be send to such reparation or product replacement.

Except in the cases mentioned above, **Promeba, S.L.** shall not give any guarantees in relation to the product, operation, accuracy, reliability or adaptability for an equipment logical purpose or any other type. If this exception is not lawful or established in the law, **Promeba, S.L.** shall limit or exclude their guarantees only to the extent that the applicable law permits it.

The only obligation of **Promeba, S.L.** regarding this warranty is to repair or replace the parts subjected to the terms and condition of this warranty.

Promeba, S.L. is not liable for loss or damages to products, this warranty or others, including economic loss or not assessable damage; the price paid for the product; loss of profits, incomes, information, usufruct or use of the product or associated products or indirect loss or damage, accidental or critical.

This clause refers to whether the loss or damage is due to a product deterioration or inoperability associated to defects or unavailability of **Promeba, S.L.** that caused a downtime, user's time loss or a business interruption.

In the cases in which the law prohibits or limits these responsibility exclusions, **Promeba, S.L.** shall exclude or limit their responsibility only to the extent that the law allows. For example, many countries forbid the exclusion or limitation of damages caused by negligence, gross negligence, willful misconduct, fraud and similar acts. The responsibility of **Promeba, S.L.** in this warranty shall not exceed, in any case, the price paid for the product, but if the applicable law permits only responsibility limitations of major responsibilities, these shall be applied.



Todos los derechos reservados. Reservado el derecho a modificaciones sin previo aviso.
Promeba, S.L. no se considera responsable de los daños causados por la falta o la inexactitud de la información aquí mencionada.

*All rights reserved. Variations can be done without notice.
Promeba, S.L. is to be considered not responsible for damages caused by the lack or the wrongness of the information here mentioned.*

SCAN QR CODE



PRODUCTOS METÁLICOS DEL BAGES S.L.

Ctra C-16 Km 59.5 · 08650 Sallent (Barcelona) · SPAIN

T. 93 837 12 00

promeba@promeba.com · www.promeba.com