



**PROMEBA**  
*EMERGENCY & RESCUE*



*USER GUIDE*

**EVACUATION CHAIR WITH TRACKS PS-187**

*Review 01/19*



# INDEX

01	INTRODUCTION	
01.1	Using this manual .....	05
01.2	Characteristics .....	06
01.2	Technical data sheet.....	06
02	INSTALATION	
02.1	Transporting and unpacking .....	07
03	OPERATING	
03.1	General elements of evacuation chair PS-187 .....	08
03.2	Chair's use .....	09
03.3.	Notes .....	09
04	GENERAL MAINTENANCE .....	11
05	LEGAL NOTICES .....	12
06	PRODUCT WARRANTY .....	13



# 01 INTRODUCTION

## 01.1 Using this manual

This manual provides using and maintenance instructions of the product, as well as the way of fixing minor faults that could appear.

It is recommended before the operation of the product to read carefully this manual in order to avoid damages caused by a misuse.

Do not lose this document, it should be accessible to any doubt that could appear by medical personnel.

Remember that a good use and maintenance are necessary for the proper operation of the product.

Each product incorporates an identification sticker with the serial number and the model. Keep these numbers so that they can be indicated to the dealer if necessary.

# 01 INTRODUCTION

## 01.2 Characteristics

1. Use for emergency situations in elderly people, public safety, hospitals, hotels, etc.
2. It can be folded. Easy storage
3. You can descend stairs continuously thanks to the tracks of the chair.
4. Four wear resistant wheels.
5. It has 4 short handles in front and behind of the backrest. It allows a better transport.



## 01.3 Technical data sheet

### MEASURES AND FEATURES //

LENGHT	800 mm
WIDTH	540 mm
HEIGHT	1420 mm
WEIGHT	12 Kg
MAX. LOAD	160 Kg
FOLDED SIZE	1200x540x350 mm

## 02 INSTALLATION

### 02.1 Transport and unpacking

First remove the packaging carefully so as not to damage the outside of the stretcher.

#### 1. Transport

- Always fix the load, if it is necessary stack. you should follow the diagram shown.
- Transport the level load and following all the precepts and regulations regarding the transport of loads.

#### 2. Unpacking

- Put the box on a flat and stable surface, open the seal carefully not to damage inside.
- Remove the product from the inside of the case as shown in the chart below.

Each product has been thoroughly inspected when leaving the factory. To ensure that the transport has not deteriorated it, please inspect the exterior and interior carefully, and in the event of any damage, contact the installer immediately.

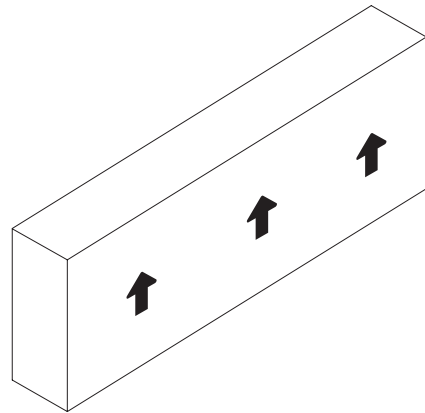

+ PACKING UNIT  
RESPECT THE PACKAGING TRANSPORT POSITION

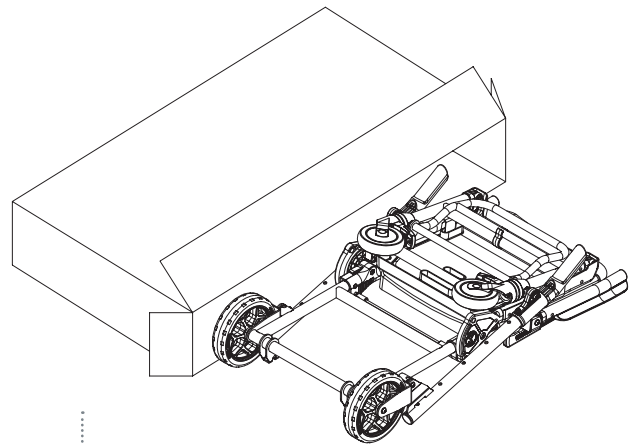

+ UNPACKING THE PRODUCT  
ALWAYS USE FLAT SURFACE

## 03 OPERATING

### 03.1 General elements of **CHAIR PS-187**

1. Backrest
2. Chair with tracks anti-slide
3. Tubular footrest
4. Completely foldable



## 03 OPERATING

### 03.2 Chair's use

1. After the patient sits down, secure the seat belts.
2. The head can be adjusted according to the height of the patient.
3. Track system: Open the chair to extend the track and the track frame will be blocked.
4. Go down the stairs:

Open the chair: push the chair to the stairs and make the chair fall back, hold the chair, make sure the chair goes in a straight line.

2 technicians are necessary to operate the chair without any damage risk both for the patients and the technicians.

### 03.3 Notes

1. The operator must read the manual first, operate the product correctly and examine it before using it, or the company will not be responsible for the risk of accidents.
2. We suggest that the man or woman who drives the chair be fit.
3. When transportation is carried out, secure the safety belts to prevent damage.
4. If you notice any damage to the chair, you should replace it immediately.
5. Check the seat belts frequently, replace the damaged parts at the same time.



## 04 GENERAL MAINTENANCE

### CLEANING

Keeping the equipment clean is essential to ensure good use and durability of the assembly. It is necessary to perform a thorough cleaning periodically, especially in areas exposed to dirt that can suffer damage such as gears, connectors, buttons, etc. Do not use high pressure washers, they may damage the electrical elements.

### CONTROLS AND SELECTORS

Due to the intense and continuous use of the movable elements, as the controls and selectors, periodically check the proper functioning of the same. There may be faults in the micro-breakers and wiring, check the fixings and electrical or mechanical connections that may exist.

### OIL

In general, any moving part must be oiled. Our products come from the factory completely oiled and lubricated, however, it is possible that with the time and use of the product the elements are decreased, either by loss of lubrication or by dirt. Clean and grease periodically affected areas, according to manufacturer's specifications.

Check for loose, missing, or worn parts. Periodically inspect all moving parts to make sure components are tight.

Due to its dry slip system, do not grease the platform guide.

**ATTENTION:** Do not lubricate the rail and / or stretcher when connected to the mains.

### WEARING AREAS

Inspecting regularly to see if there is wear on the system components is a preventive measure that can reduce breakdowns. Check for possible lubricant leaks, grooves or bearings in poor condition.

### MECHANICAL FASTENING ELEMENTS

In general, we call mechanical fastening elements for the components that are used to fix the whole of the product, mainly fasteners and derivatives.

In some conditions of use, due to vibrations and impacts, certain elements can lose their tightening torque or fixing properties.

Check periodically that there are no loose elements, especially in moving parts of the assembly. Always observe the recommended tightening torques.

### REPLACEMENT OF COMPONENTS

This instruction manual does not include procedures for all parts. Typically, qualified service personnel replace wires, switches and certain mechanical parts without the need for step-by-step procedures.

Qualified service personnel should contact our sales department for information on ordering parts and installing them.



MAKE SURE THESE ZONES ARE FREE OF WATER AND MOISTURE. PLEASE SPECIFY CAREFULLY WITHOUT WETTING THEM DURING THE WASHING OF THE ASSEMBLY.

## 05 LEGAL NOTICES

This document may contain technical inaccuracies or typographical errors.

Periodic changes are made to the information contained herein; These changes will be incorporated in new editions of the publication.

**Promeba, S.L.** Reserves the right to make any changes or improvements to the products described in this publication, if deemed appropriate.

**Promeba, S.L.** May have patents or pending patent applications addressing issues described in this document. The possession of this document does not confer any license on said patents.

The information contained in this document does not affect or change the specifications or warranties of the product **Promeba, S.L.**

No part of this document shall be construed as an express or implied license or indemnification under the intellectual property rights of **Promeba, S.L.** Or third parties.

All information contained in this document has been obtained in specific environments and is presented as an illustration. Results obtained in other operating environments may vary.

**Promeba, S.L.** may use or distribute the information provided by the customer in a way that creates timely, without incurring any obligation with the client.

## 06 PRODUCT WARRANTY

**Promeba, S.L.** ensures that your products have passed satisfactorily all the established quality controls, both functional and material. The duration of the warranty is 2 years from the date of purchase of the product.

This warranty is valid only when it is presented with the original invoice or proof of purchase (indicating the date of purchase, model and dealer name) together with the defective product during the period covered by the warranty. **Promeba, S.L.** reserves the right not to offer the free warranty service if the indicated documents are not presented or if the information they contain is incomplete or illegible.

*1. This warranty does not apply if the model name or serial number of the product has been altered, deleted, disappeared or is unreadable.*

*2. This warranty does not cover transport costs or the risks associated with transporting your product to and from **Promeba, S.L.***

*3. This warranty does not cover any of the following:*

*a) Periodic maintenance and repair or replacement of parts derived from normal wear and tear.*

*b) Periodic maintenance and repair or replacement of consumables (components that are expected to require periodic replacement during the life of the product, such as non-rechargeable batteries, bulbs, etc.). Parts from normal wear and tear....*

*c) Damage or defects arising from improper use, operation or treatment of the product and not from normal use of the product.*

*d) Damage arising from:*

i. Misuse, including:

- Treatment resulting in damage or changes in the physical, surface or appearance of the product.

- Installation, use or storage of the product in a manner that does not comply with the instructions described by **Promeba, S.L.**

- Maintenance of the product in a manner that does not comply with the instructions of **Promeba, S.L.** for proper maintenance.

- Installation or use of the product in a manner that does not respect the technical or safety standards of the country where it is used or installed.

ii. Use of components not provided with the product or improper installation of accessory parts not previously tested.

iii. States or defects of the system in which the product is used or incorporated with the exception of other products **Promeba, S.L.** designed for use with the product.

iv. Use of the product with accessories, peripheral units and other products of a type, condition or standards not established by **Promeba, S.L.**

v. The manufacturer or distributor will be solely responsible for deciding the shipment of the parts for repair, or replacement of the product in its entirety. In no case will workers be sent for such repair or replacement of the product.

Except in the cases mentioned above, **Promeba, S.L.** shall not give any warranties with respect to the product, performance, accuracy, reliability or adaptability to a purpose of the logical or other equipment. If this exception is not lawful or contemplated by the current law, **Promeba, S.L.** limit or exclude its warranties only to the extent permitted by law.

The only obligation on the part of **Promeba, S.L.** in connection with this warranty is to repair or replace the parts subject to the terms and conditions of this warranty.

**Promeba, S.L.** is not responsible for the loss or damage of products, this warranty or others, including economic loss or non-evaluable damages; The price paid for the product; Loss of profits, income, information, usufruct or use of the product or associated products or indirect, accidental or critical loss or damage.

This clause refers to whether the loss or damage is due to deterioration or inoperability of the associated product due to defects or unavailability of **Promeba, S.L.**, which has caused a downtime, loss of user time or a business interruption.

In cases where the law prohibits or limits these exclusions of liability, **Promeba, S.L.** exclude or limit its liability only to the extent permitted by applicable law. For example, there are countries that prohibit the exclusion or limitation of damages caused by negligence, reckless negligence, willful misconduct, fraud, and similar acts. The responsibility of **Promeba, S.L.** in this warranty will not exceed, in any case, the price paid for the product, but if the current law allows only limitations of greater responsibilities, these will apply.



*All rights reserved. Variations can be done without notice.  
Promeba, S.L. is to be considered not responsible for damages caused by the lack or the wrongness  
of the information here mentioned.*

SCAN QR CODE



PROMEBA, S.L.

Ctra C-16 Km 59,5 · 08650 Sallent (Barcelona) · SPAIN  
T. 93 837 12 00 · Fax 93 820 61 08  
promeba@promeba.com · www.promeba.com