



USER GUIDE
STRETCHER SERIE PC-900/7

REV. 2025/01

00 TABLE OF CONTENTS

REV. 2025/01

01	MODELS.....	3
01.1	Products.....	3
01.2	Accessories.....	3
02	INTRODUCCIÓN.....	5
02.1	Using this guide.....	5
02.2	Legend of symbols.....	5
02.3	Service request.....	6
02.4	Life span.....	6
02.5	Demolition.....	6
02.6	Reference standards.....	6
02.7	Labelling.....	7
03	INTENDED USE.....	8
03.1	Intended use.....	8
03.2	Contraindications and side effects.....	8
03.3	Physical requirements of the operators.....	8
04	WARNINGS.....	9
04.1	General warnings.....	9
04.2	Specific warnings.....	11
04.3	Residual risk.....	12
05	DESCRIPTION OF THE PRODUCT.....	13
05.1	Main components.....	13
05.2	Technical data sheet.....	16
05.3	Main components (accessories).....	17
05.4	Technical data sheet (accessories).....	20
06	OPERATION.....	21
06.1	Transport and storage.....	21
06.2	Preparation.....	21
06.3	Functioning.....	23
06.4	Troubleshooting.....	29
07	GENERAL MAINTENANCE.....	30
07.1	Cleaning.....	30
07.2	Lubrication.....	30
07.3	Wear areas.....	30
07.4	Maintenance program.....	31
08	SPARE PARTS.....	32
09	TRAINING REGISTER.....	34
10	MAINTENANCE REGISTER.....	35
11	LEGAL NOTICES.....	36
12	PRODUCT WARRANTY.....	37

01 MODELS

REV. 2025/01

01.1. Products

REFERENCE	UDI CODE	TRADE NAME
PC9017-00000	8436601871145	AMBULANCE STRETCHER PC-901/7
PC9010-00000	8437021314359	AMBULANCE STRETCHER PC-901
PC9027-00000	8436601871084	AMBULANCE STRETCHER PC-902/7
PC9020-00000	8437021314366	AMBULANCE STRETCHER PC-902
PC9117-00000	8436601871121	AMBULANCE STRETCHER PC-911/7 PERFORMANCE
PC9110-00000	8437021314373	AMBULANCE STRETCHER PC-911
PC9127-00000	8436601871107	AMBULANCE STRETCHER PC-912/7
PC9120-00000	8437021314380	AMBULANCE STRETCHER PC-912
PC9130-00000	8437021314397	AMBULANCE STRETCHER PC-913
PC9217-00000	8436601871183	AMBULANCE STRETCHER PC-921/7
PC9210-00000	8437021314427	AMBULANCE STRETCHER PC-921
PC9227-00000	8436601871138	AMBULANCE STRETCHER PC-922/7
PC9220-00000	8437021314434	AMBULANCE STRETCHER PC-922
PC9510-00000	8437021314441	AMBULANCE STRETCHER PC-951 FOWLER
PC9520-00000	8437021314458	AMBULANCE STRETCHER PC-952 FOWLER

01.2. Accessories

REFERENCE	UDI CODE	TRADE NAME
PA5351-00000	8437001519941	LOCKING SET 3 POINTS PA-5351
PA5352-00000	8437001519958	LOCKING SET 3 POINTS PA-5352
PA5500-00000	8437001519965	UNIVERSAL LOCKING SET PA-550
PA-750	8437021314694	FRAMEPROOF SEALED MATTRESS PA-750
PA-632	8437021314700	SEALED PROMEBA MATTRESS PA-632

01 MODELS

REV. 2025/01

PC6100-05000B	8437021314960	FOLDING INSTRUMENT TABLE
PA5250-00000	8437021314977	OXYGEN BOTTLE HOLDER
PA7600-00000A	8436601870773	BARIATRIC KIT FOR SERIE PC-900
PA-235	8436601870285	TRANSFER TABLE - FOLDABLE

02 INTRODUCTION

REV. 2025/01

02.1. Using this guide

The manual provides instructions for use and maintenance of the product, as well as technical aspects, operation, spare parts and safety.











It is recommended before the operation of the product to read carefully this manual in order to avoid damages caused by a misuse, regardless of the level of experience acquired in the past with similar devices.

Do not lose this document. It should be accessible to any doubt that could appear by medical personnel. In case the device has some instructions for use of a different product than the one received, it is necessary to contact the manufacturer immediately before using the product.

Remember that a good use and maintenance are necessary for the proper operation of the product.

Each product includes an identifying adhesive label with the serial number and model. Keep these numbers so that you can refer them to the dealer if necessary.

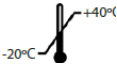
02.2. Legend of symbols

SYMBOL	EXPLANATION / DESCRIPTION
	MANUFACTURER symbol. This symbol is accompanied by the name and address of the manufacturer, adjacent to the symbol (PRODUCTOS METÁLICOS DEL BAGÉS S.L., Ctra. C-16 Km 59.5, 08650 Sallent (Barcelona)).
	Indicates the manufacturer's reference number to identify the medical device. PROMEBA, S.L. uses this symbol to set each internal reference for each configuration and business variant
	Indicates the manufacturer's serial number to identify a specific medical device.
	Indicates the manufacturing date. The symbol must be accompanied by a manufacturing date (yyyy-mm), adjacent to the symbol.
	Symbol for the Unique Device Identifier.
	Symbol "See instructions for use or operating instructions"
	Symbol "caution". This symbol is placed to warn of the need for the user to refer to important precautionary information in the operating instructions, such as warnings and cautions not otherwise found on the label.
	Symbol "Caution". For a general warning.
	Warning, crushing of hands
	Indicates the temperature limits. The upper and lower temperature limits should be indicated adjacent to the horizontal lines.
	It is placed to inform that the product is a "Medical Device"
	CE symbol without the intervention of a Notified Organism, as a Medical Device classified as Class I according to the EU Regulation 2017/745 on Medical Devices.

02 INTRODUCTION

REV. 2025/01



Symbol for the Unique Device Identifier.

02.3. Service request

For information of the correct interpretation of the instruction manual, the use, maintenance, installation and restoration of the product, please contact Promeba customer service: T. 93 837 12 00, email: promeba@promeba.com or write to PROMEBA, S.L. - Ctra C-16 Km 59.5 · 08650 Sallent (Barcelona) · SPAIN.

Whenever you want to communicate any matter related to a product, you will be asked for the product reference () and the serial number (). It is strongly recommended to keep the label containing this information and found on the original packaging of the product.

02.4. Life span

If used as described in the following instructions, this device has a useful life of 10 years from the date of purchase.

This useful life can be extended with annual reviews carried out by the manufacturer, which uses specialized and authorized internal and external technicians.

In case these annual checks are not carried out, the device must be disposed of according to the information in paragraph 02.5 and the manufacturer must be notified.

Only the manufacturer or an authorized center can extend the life of the device, if it meets the safety and legal requirements.

Promeba, S.L. will not accept any responsibility for malfunction or damage caused by the use of devices that have not been checked by the manufacturer or authorized center, or that have exceeded the maximum allowed useful life.

02.5. Demolition

When the devices are no longer suitable for use, if they have not been contaminated by any particular agent, they can be disposed of as normal solid waste, otherwise, follow the current demolition regulations.







02.6. Reference standards

REFERENCE	TITLE OF DOCUMENT
Regulation (EU) 2017/745 and 2024/1860 (EU)	Medical devices
EN 1789:2007+A2:2014	Medical vehicles and their equipment - Road ambulances
UNE-EN 1865-1:2012	Patient handling equipment used in road ambulances - Part 1: General stretcher systems and patient handling equipment



As a distributor or end user of the products manufactured and/or distributed by Promeba, S.L., you are strictly obliged to know the legal provisions in force in the country of destination of the goods, applicable to the devices to be supplied (including the regulations relating to technical specifications and/or safety requirements) and, therefore, understand the necessary requirements to ensure compliance of the products themselves with all the legal requirements of the territory.

02.7. Labelling

Each product incorporates an identification label, placed on the device itself and/or on the original packaging of the product. It must never be removed or covered. This label includes the data of the company which produced the device () , the product code / reference () of the product, the manufacturing date () , the serial number () , the UDI-PI code () and the CE distinctive () . Please keep these numbers so you can inform the dealer if necessary.



PROMEBA
Productos Metálicos del Bages, S.L.
 Ctra. C-16 km. 59,5 - 08650 - SALLENT - BARCELONA (SPAIN)

Rev. 2021/06
 +40°C
 -20°C

REF **PC9900-00000**

2024-49

SN **0155/49/24/001**

UDI **(01)08436601870452(11)241202(21)01554924001**

The UDI-PI code is made up of the following fields:

- (01)08436601870452: UDI code of the product.
- (11)241202: it gives information about the batch release date of the product following the format *yyymmdd*, where *yy* is the batch release year, *mm* is the month of the batch release and *dd* is the day of the batch release.
- (21)01554924001: identifies the serial number of the product giving information about the manufacturing order (0155) including the week when the product was produced (4924) and a correlative number depending on the units that has been produced in that production order (001).

03.1. Intended use

The product MANUAL STRETCHER SERIE 900/7 is indicated to load and transport with the less effort possible any type of patient in a cot or neonatal incubator in hospital and pre-hospital environments, including the transport with ambulances.

03.2. Contraindications and side effects

Any contraindication or side effect have been resulted from the clinical analysis of the STRETCHER SERIE PC-900/7 family of products.

03.3. Physical requirements of the operators

The Promeba manual stretchers serie PC-900/7 are intended exclusively for professional use. Each operator must be trained to transport patients safely and efficiently. Do not allow untrained persons to assist during use of the product, as they may cause injury to others, to patients or themselves. The device is intended to be used by ambulance or rescue technicians who have knowledge and experience with the transportation of patients in emergencies.

Operators must be able to provide the necessary assistance to the patient.

Users must be able to safely lift and manipulate the weight of the assembly consisting of the stretcher, the patient, and any other equipment used with the device.

For patient loading techniques, for particularly heavy patients, for interventions on steep terrain or in particular and unusual circumstances, the presence of several operators is recommended (not just 1 as expected in standard conditions).

Operators must be able to evaluate any anomaly of the system/assembly, communicating the problem to those responsible and interrupting the use of the devices if necessary to ensure patient safety.



The capabilities of the different operators must be considered before determining their role.

04.1. Advertencias generales

1. The product must be used by trained personnel only, having attended specific training for this device and not for similar products.
2. Establish a maintenance and periodic control program and identify a reference manager. The person in charge of the ordinary maintenance of the device must guarantee the basic requirements provided by the manufacturer in these instructions for use. It is recommended that the subject check at least every 6 months if there are updated user manuals available or if there are any changes related to his / her product. This information is freely available on the website <http://promeba.com/>.
3. Training routines must be registered on a special register in which the names of those trained, of the trainers, date and place are indicated. This register, which will certify the eligibility of the operators to use the Promeba, S.L. device, has to be kept for a period of 10 years after the disposal of the device itself. This register will be made available to the competent authorities and/or manufacturer if requested.
4. Promeba, S.L. is always at your disposal to plan trainings on products.
5. Before carrying out any kind of operation on the appliance (training, installation, use), the operator must carefully read the enclosed instructions, paying particular attention to the correct safety precautions and to the procedures to be followed for installation and for correct use.
6. If the instructions belong to another device and not the device received, inform the manufacturer immediately and avoid use of the device.
7. In the case of any doubts as to the correct interpretation of the instructions, please contact Promeba, S.L. for any necessary clarifications.
8. Do not allow untrained persons to help during the use of the device, because they could cause damage to the body or to themselves.
9. Before each use of device the perfect operating state of the device must be checked as specified in the instruction manual. If any damage or abnormalities which could in any way influence the correct functioning and the safety of the device and/or of the user are detected, the device must be immediately removed from service and the manufacturer must be contacted.
10. If any failure or incorrect functioning of the device is detected, it must be immediately substituted with a similar item so that the rescue procedures are guaranteed without any interruption.
11. Use of the device in anyway other than described in this manual is forbidden.
12. Do not alter or modify in any way the device; any such interference could cause malfunctions and injury to the operators.
13. The device must not in any way be tampered with (modification, adjustment, addition, replacement). In such cases all responsibility will be denied for any malfunctions or injuries caused by the device itself; moreover product warranty will be considered void.

04 WARNINGS

REV. 2025/01

14. Use only original or PROMEBA approved components/spare parts and/or accessories to carry out all operations without causing alterations or modifications to the device; otherwise, any responsibility for the operation is declined.
15. Ensure that all the necessary precautions are taken in order to avoid the hazards that can arise as the result of contact with blood or body fluids.
16. Register and store with these instructions: lot number, place and date of purchase, first date of use, date of checks, name of users and any other comments.
17. When the device is being used, the assistance of qualified staff must be guaranteed.
18. The product must not be exposed or come into contact with thermal sources of combustion and flammable agents, but must be stored in a dry, cool place, protected from light and sunlight.
19. Store and transport device in its original packaging.
20. Do not store the product under other more or less heavy materials, which can damage the structure of the product.
21. Attention: laboratory testing, post production tests and instruction manuals cannot always consider every possible scenario for use. This means that in some cases the performance of the product could be notable different from results to date obtained. Instructions are continually being updated and are under tight surveillance of fully qualified staffs with adequate technical formation.
22. As a distributor or end users of products manufactured and/or marketed by Promeba, S.L., you are strictly required to have a basic knowledge of any legal requirements existing in the goods final destination country applying to the devices contained in this supply (including laws and norms regarding technical specifications and/or safety requirements) and therefore you are also strictly required to have the necessary knowledge to guarantee all aspects regarding the total conformity of the products to the regulations in the relevant territory.
23. Promptly notify PROMEBA regarding any revisions to be made by manufacturer in order to guarantee the conformity of the product to the territory's legal specifications (including those resulting from rules and/or norms of other nature).
24. Act with all due care and diligence, and contribute to ensure conformity to general safety requirements of all devices marketed in the territory, by providing final users with all necessary information for carrying out periodical checks on their devices, as specified in the relevant user manual.
25. Actively contribute to product safety checks on products sold, by communicating any relevant risk analysis information both to the manufacturer and to any competent authorities so that the necessary actions can be promptly taken.
26. Be aware that in the event of any failure to conform to the above mentioned requirements you will be deemed fully responsible for all damages that might occur. Therefore we expressly disclaim any responsibility and/or liability for your non-compliance with the present "Regulatory provisions".
27. Follow internal procedures and protocols approved by your organization.

28. Follow Emergency Medical Service approved procedures for patient immobilization and transport.

04.2. Specific warnings

1. Use only accessories/spare parts that are original or approved by Promeba, S.L. when performing any operation so as not to cause any alteration or modification to the device, otherwise we do not assume any responsibility for the correct operation or resulting damage of the device to the operator and the guarantee will be considered void.
2. Always respect the maximum capacity of the device, as indicated in this user's manual. Maximum load capacity means the total weight distributed according to the human anatomy. In determining the load of the total weight on the product, the operator must consider the weight of the patient, the equipment and the accessories. Moreover, the operator must consider that the overall dimensions of the patient do not reduce the functionality of the device.
3. Inside the ambulance, place and adjust the device taking care not to obstruct other parts or other equipment. It is recommended not to open the equipment inside the ambulance, but rather to do it outside the vehicle.
4. Never leave the patient unassisted on the device.
5. Do not use bleach to disinfect the device. Use a hydroalcoholic based disinfectant and wash with water.
6. The device and all its components, after washing, should be allowed to dry completely before storing.
7. Avoid contact with sharp objects.
8. Do not use the device if it is pierced, deformed or shows signs of loss of integrity.
9. Do not operate in case the weight has not been distributed correctly.
10. Condensation, water, ice and dust accumulations can affect the correct operation of the device, making it unpredictable.
11. Always immobilize the patient at least with the belts supplied by the manufacturer during any movement of the stretcher, including loading and unloading to the ambulance.
12. Do not use the device as a support for climbing or leaning on and reaching high points in the vehicle. The product may be damaged and the technician may be harmed.
13. Disinfection activities must be carried out in accordance with the validated cycle parameters, indicated in the specific technical standards.
14. Promeba S.L. shall not be liable if unauthorized / incompatible stretcher fastener is used.
15. Do not exceed the maximum capacity allowed by the stretcher. Exceeding it may cause deformations to the product or harm to the operator.

04 WARNINGS

REV. 2025/01

16. Always use both hands to transport the stretcher to avoid the risk of tipping over.
17. Pay full attention to the team and the patients during the performance of the service.
18. Pay a lot of attention to possible obstacles (water, ice, gravel, etc.) on the route of the stretcher, because it could cause loss of balance for the operator and compromise the proper functioning of the device. If you can not set the path free from obstacles, choose an alternative path.
19. For gradients or steps greater than 10 mm, the device must be raised, taking care to grasp the structure and not from the banks/platforms.
20. Improper installation of the loading platform may cause structural damage and consequent injury to the weldings of the front legs.
21. Improper installation of the loading platform may cause undesired operation of the device and cause harm to the operator.
22. Replace the wheels with original parts in case of failure and stop the device.

04.3. Residual risk

The residual risks listed below have been identified only with reference to the intended use of the device:

1. The operation carried out by unqualified personnel could cause harm to the personnel performing the operation, the patients or other third people.
2. Improper disinfection procedures may lead to a risk of cross contamination.
3. Failure to lock or position it correctly the device into the fixation system could result in sudden and dangerous movements, which could cause injury to operators and/or the patients.
4. Partially opening the legs may cause the stretcher to fall to the ground. Ensure that the legs are properly locked before any manipulation and that the pistons are fully extended and stable.

05 DESCRIPTION OF THE PRODUCT REV. 2025/01

05.1. Main components

PC9017-00000 AMBULANCE STRETCHER PC-901/7
PC9027-00000 AMBULANCE STRETCHER PC-902/7
PC9217-00000 AMBULANCE STRETCHER PC-921/7
PC9227-00000 AMBULANCE STRETCHER PC-922/7

N°	DESCRIPTION OF THE COMPONENTS	N°	DESCRIPTION OF THE COMPONENTS
1	Matress	7	Red folding handle for front legs
2	Belts	8	Green folding handle for rear legs
3	Front legs	9	Telescopic handles
4	Rear legs	10	Loading wheels
5	Brakes	11	10G anchor
6	Rear wheels with possible locking		

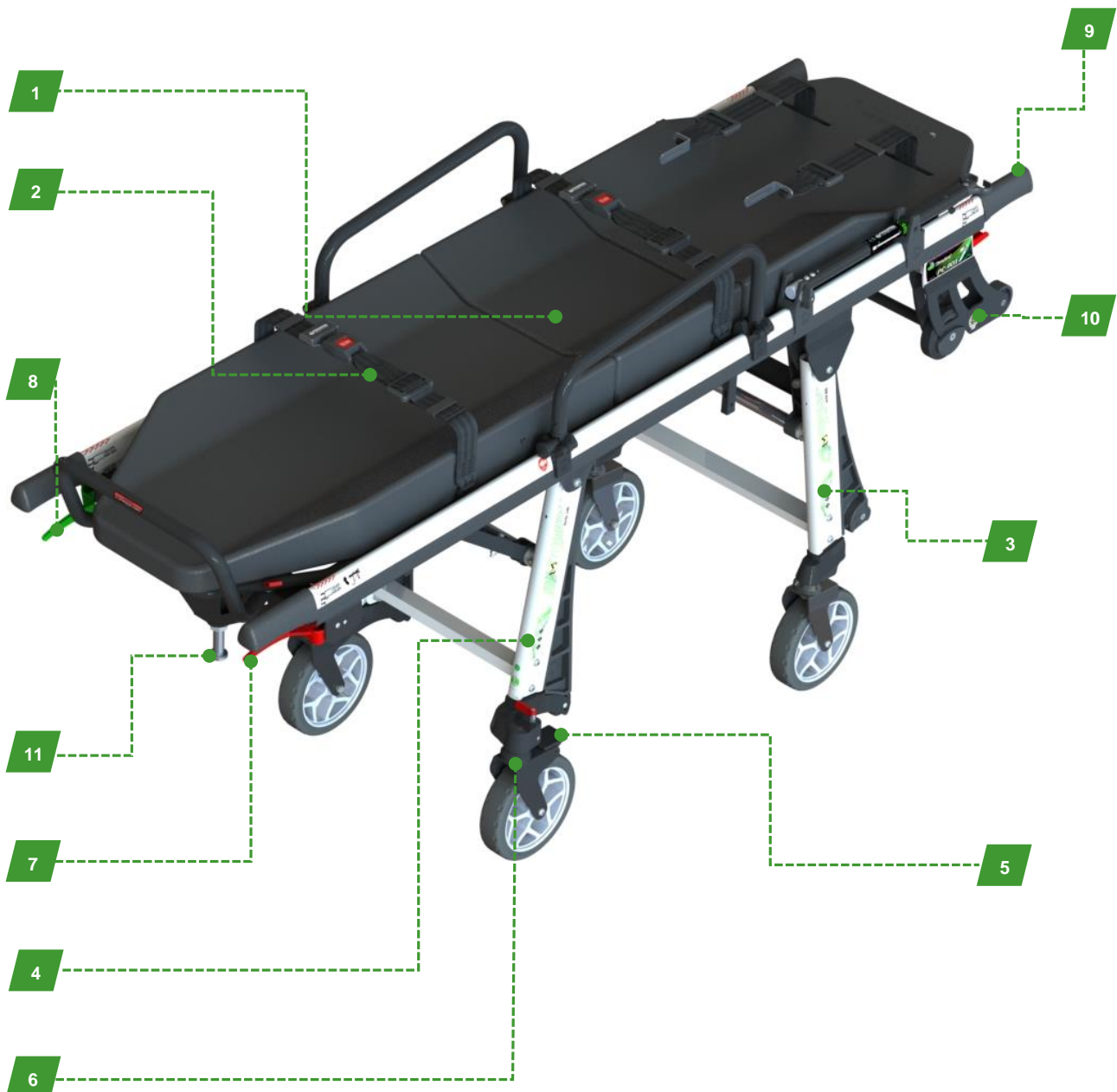

PC9117-00000 AMBULANCE STRETCHER PC-911/7 PERFORMANCE
PC9127-00000 AMBULANCE STRETCHER PC-912/7
PC9130-00000 AMBULANCE STRETCHER PC-913

Nº	DESCRIPTION OF THE COMPONENTS	Nº	DESCRIPTION OF THE COMPONENTS
1	Matress	7	Red folding handle for front legs
2	Belts	8	Green folding handle for rear legs
3	Front legs	9	Telescopic handles
4	Rear legs	10	Loading wheels
5	Brakes	11	10G anchor
6	Rear wheels with possible locking	12	Quick Lock System

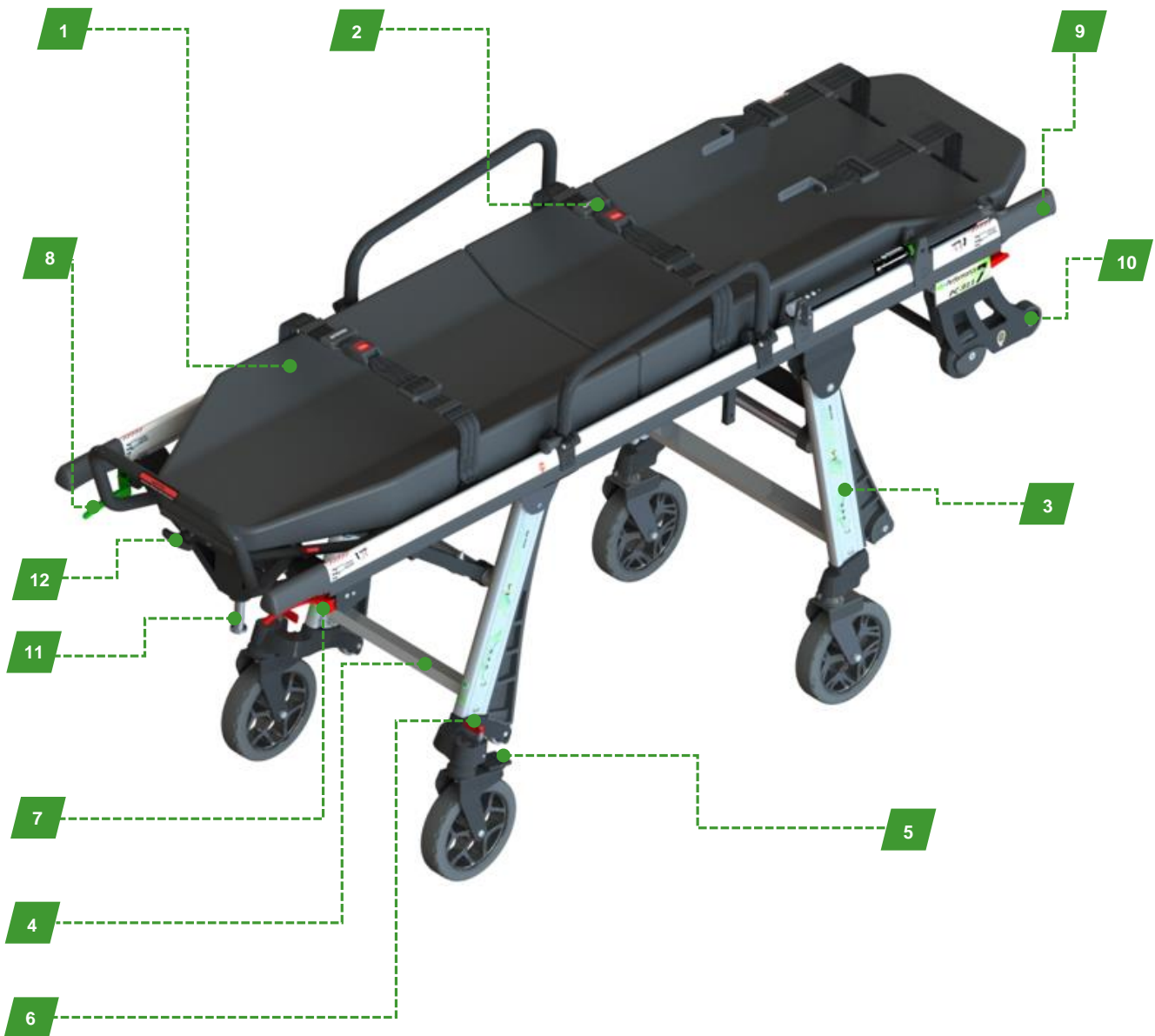

05 DESCRIPTION OF THE PRODUCT REV. 2025/01

PC9510-00000 AMBULANCE STRETCHER PC-951 FOWLER
PC9520-00000 AMBULANCE STRETCHER PC-952 FOWLER

N°	DESCRIPTION OF THE COMPONENTS	N°	DESCRIPTION OF THE COMPONENTS
1	Matress	7	Red folding handle for front legs
2	Belts	8	Green folding handle for rear legs
3	Front legs	9	Telescopic handles
4	Rear legs	10	Loading wheels
5	Brakes	11	10G anchor
6	Rear wheels with possible locking	12	Quick Lock System



05 DESCRIPTION OF THE PRODUCT REV. 2025/01

05.2. Technical specifications / data sheet

Models	PC9017-00000	PC9027-00000	PC9117-00000	PC9127-00000	PC9130-00000	PC9217-00000	PC9227-00000	PC9510-00000	PC9520-00000
Length [mm]	1940	1940	1940	1940	1940	1940	1940	1940	1940
Width [mm]	560	560	560	560	560	560	560	560	560
Height [mm]	940	1040	940	1040	1080	940	1040	940	1040
Weight [kg]	42	43	43	44	46	42,5	43,5	43,5	44,5
Max. Load [kg]	250	250	250	250	250	250	250	250	250
Fowler	NO	NO	NO	NO	NO	NO	NO	SÍ	SÍ
Trendelemburg	17°	17°	17°	17°	17°	17°	17°	17°	17°
Quick Lock	NO	NO	SÍ	SÍ	SÍ	NO	NO	SÍ	SÍ
Ergo Load	NO	NO	SÍ	SÍ	SÍ	NO	NO	SÍ	SÍ
Front wheels blocked	NO	NO	NO	NO	NO	SÍ	SÍ	NO	NO

05 DESCRIPTION OF THE PRODUCT REV. 2025/01

05.3. Main parts (accessories)

PA5351-00000 LOCKING SET 3 POINTS PA-5351

N°	DESCRIPTION OF THE COMPONENTS
1	Ergonomic handle to unlock the stretcher
2	Non-slip textured adhesive
3	Tube structure. Universal locking system

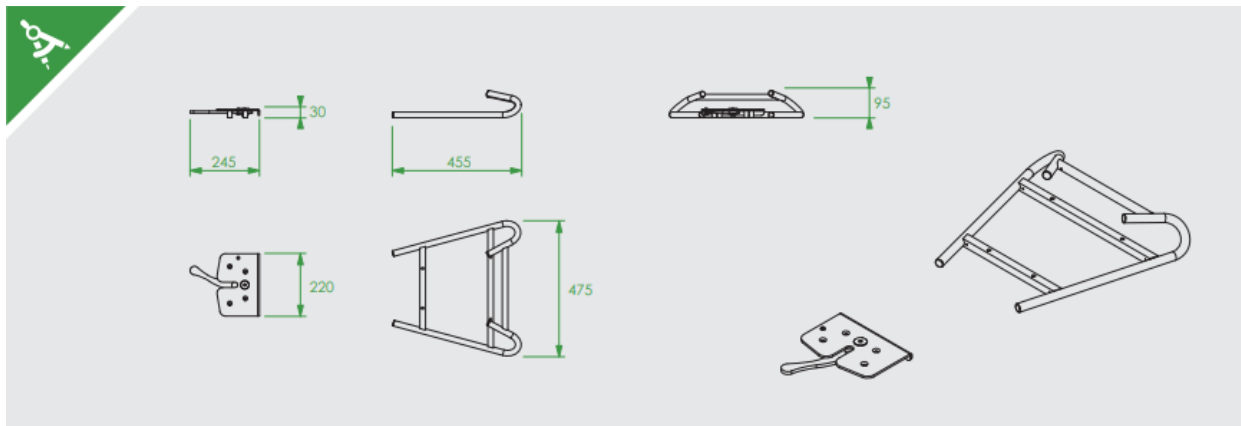
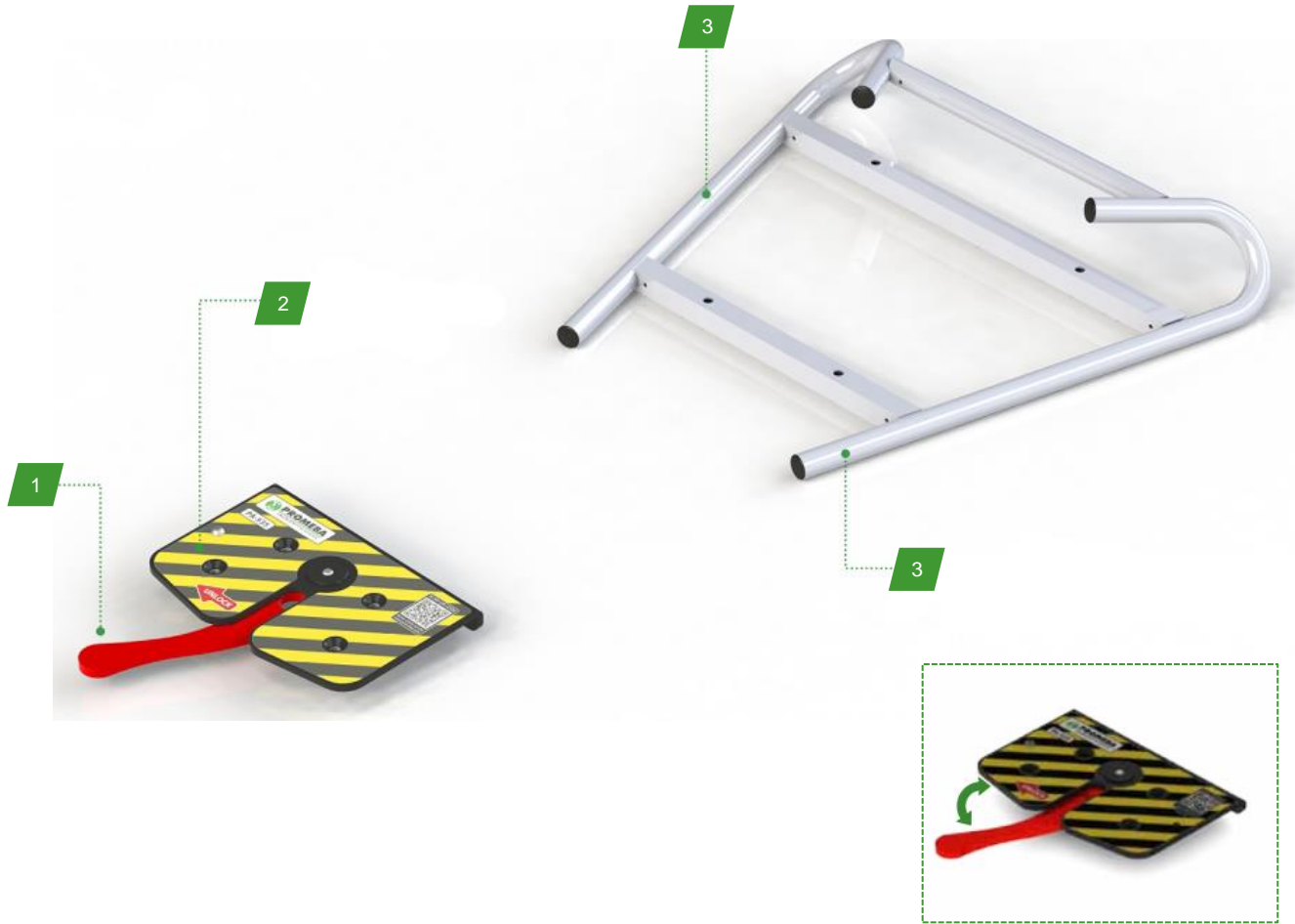

05 DESCRIPTION OF THE PRODUCT REV. 2025/01

PA5352-00000 LOCKING SET 3 POINTS PA-5352

N°	DESCRIPTION OF THE COMPONENTS
1	Ergonomic handle to unlock the stretcher
2	Non-slip textured adhesive
3	Locking hooks

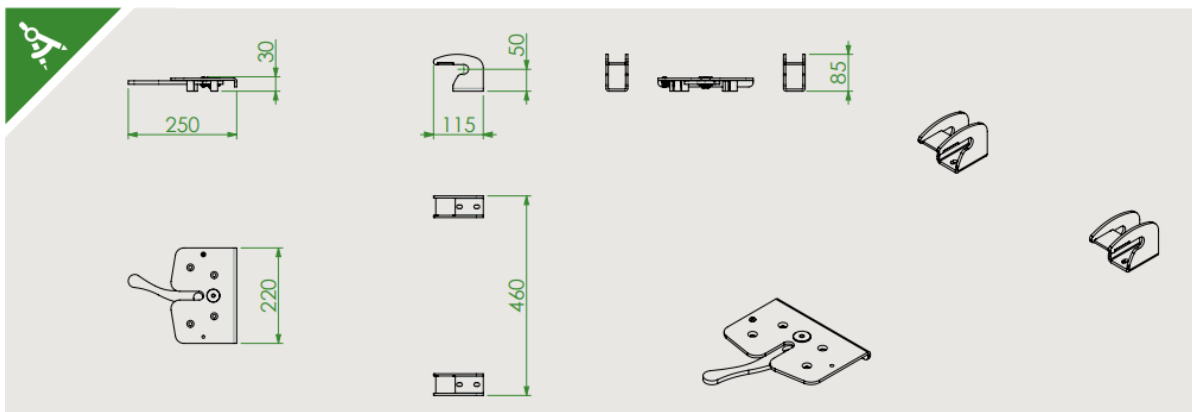
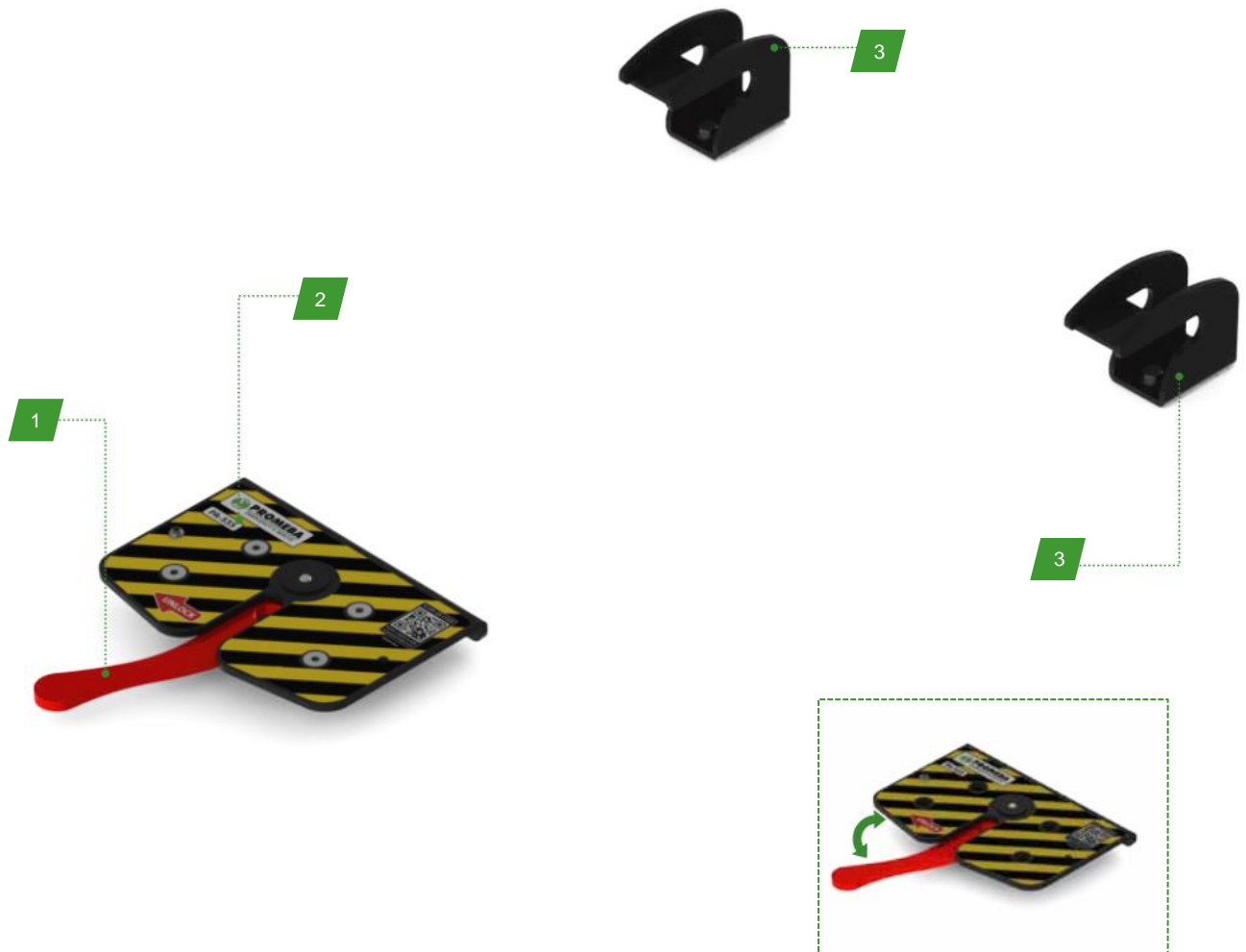

05 DESCRIPTION OF THE PRODUCT REV. 2025/01

PA5500-00000 UNIVERSAL LOCKING SET PA-550

N°	DESCRIPTION OF THE COMPONENTS
1	Tubular structure with handle and hooks
2	Non-slip textured adhesive

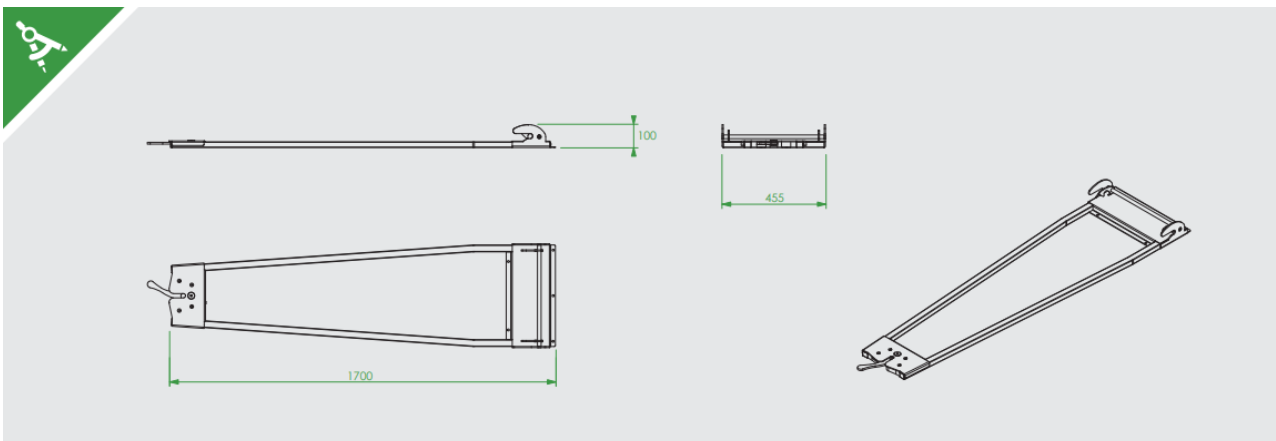
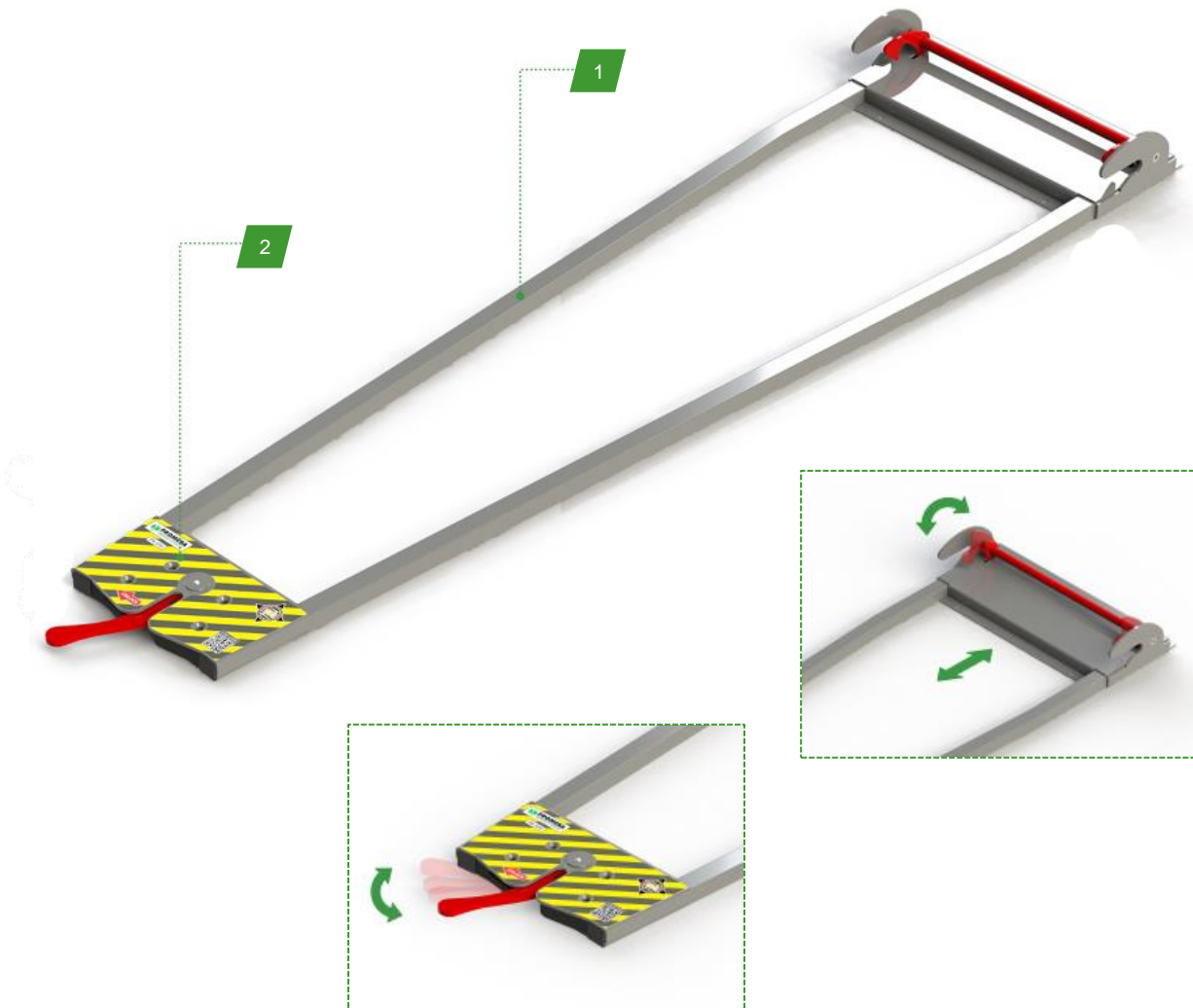

05 DESCRIPTION OF THE PRODUCT REV. 2025/01

05.1. Technical specifications / data sheet (accessories)

Models	PA5351-00000	PA5352-00000	PA5500-00000
Length	245/455mm	250/115mm	1700mm
Width	220/475mm	220/460mm	455mm
Height	95mm	85mm	100mm
Weight	10kg	8kg	12kg
Max. Load	250kg	250kg	250kg
Suitable for	Universal	PC-900 stretchers	Universal

06 OPERATION

REV. 2025/01

06.1. Transport and storage

Before transporting the appliance, make sure that it is correctly packaged. During transport always fix the load. If piling up is necessary, always follow the scheme shown on figure 1. Transport the load levelled and following all precepts and rules for the load transportation, ensuring also that there are no risks of shocks, bumps or falls during the transport itself.

To unpack the device place the box on a flat, stable surface and carefully open the seal. Remove the device from the inside of the box following the scheme shown on figure 2. Keep the original packaging for use in case of any other transport and for storage.

Damage to the appliance caused during transport and handling is not covered by the guarantee. Repairs or replacement of the damaged parts are the responsibility of the client.

The device must be stored in a dry, cool area away from direct sunlight. It must not be placed in contact with any substances or chemical agent which could cause damage and reduce safety characteristics.

The storage temperature must be between -20°C and 60°C.

Packaging characteristics:

SIZE: 2000 x 800 x 530 mm

WEIGHT: 60 Kg.

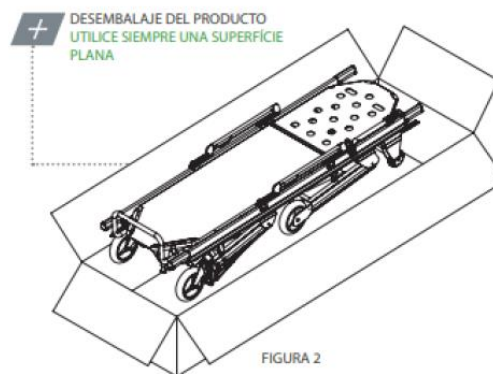
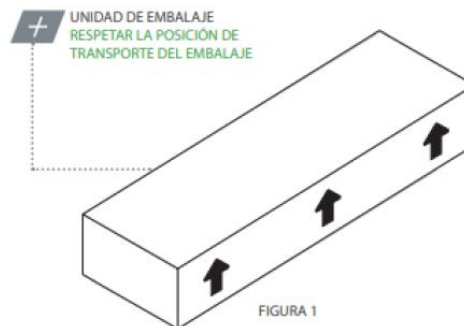

The product must not be manipulated in any way (modification, adjustment, addition, substitution). In such cases, all responsibility for any malfunction or injury caused by the product itself will be disclaimed; furthermore, product warranty will be considered void.

06.2. Preparation

When the product is received:

- Verify that the packaging is intact and has no signs of impacts, falls and isn't wet.
- Remove the packaging and expose the material so that all components are visible.
- Check that all the components/pieces on the section 5 are present.

The appliance must be checked before every use so as to reveal any working abnormalities and/or damage caused by transport and/or storage. In particular, check:

- General functionality of the device.

06 OPERATION

REV. 2025/01

- Cleaning the device (remember that the lack of cleaning can cause the spread of infections).
- Absence of cuts, holes, breaks in the structure, including the belts.
- Correct fixing of all nuts, bolts and screws.
- Correct attachment of the belts to the stretcher.
- Correct operation of the belt closure.
- Condition of moving parts, wheels and belts.
- There are no tubes or metal sheets that show bends or cracks.
- The tray of the stretcher do not show damage or structural cracks.
- The welds are intact, without cracks or breaks.
- Wheels are securely fixed, stable and work properly.
- Wheels are free of dirt or debris.
- Brakes work properly.
- The transport handles open, close and lock correctly.
- Telescopic handles open, close and lock properly.
- Presence of all labeling.
- Lubrication of moving parts.
- The vehicle is equipped with the locking system for the stretcher.

If the above conditions are met, the device may be considered ready for use; otherwise it must immediately be removed from service and contact the manufacturer.

REQUISITOS DEL VEHÍCULO

The Promeba stretcher has been designed to enter and exit the patient to the compartment of the ambulance. The vehicle must have a levelled loading platform, wide and long enough for the Promeba stretcher and without obstacles.

To configure the height of the platform you must take into account these two requirements:

- Maximum loading height: you can check the height of each stretcher model in the table of the section 05.2.
- Minimum loading height: when the loading wheels are placed on the platform and the front legs touch the platform, the front wheels must be at least 50 mm from the ground (see figure 3)



Figura 3



Failure to comply with these requirements may result in malfunctioning of the opening and closing of the legs. The legs may not lock when they reach the ground, causing the patient to fall and risk of injury to the operator.

The measurement of the loading platform must be taken with the vehicle positioned on a uniform and perfectly horizontal surface and with two operators seated in the patient compartment (simulating a load of approximately 250 kg).

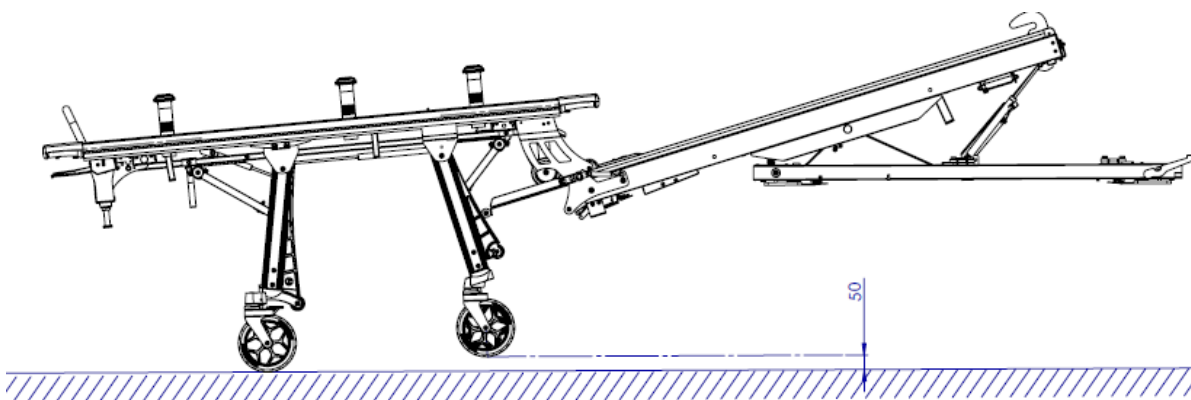
If the vehicle is equipped with pneumatic or hydraulic suspensions, the loading height adjustment must be carried out taking into account the worst conditions of use and/or the operating one provided by the vehicle builder. Problems during use and/or safety risks associated with such system, cannot be attributed to the manufacturer.

Try out the loading and unloading procedures with an empty stretcher before putting the stretcher into regular service.

TRANSFER / LOAD OF THE PATIENT

Before loading the patient, move the stretcher as close as possible to him / her, if it is necessary for facilitating the operations, position the stretcher in the intermediate height (paragraph 06.3). Follow internal protocol for transferring and loading patients.

06.3. Functioning

STRETCHER CIRCULATION

When the stretcher is circulating, the following indications must ALWAYS be observed:

- Ride on flat ground, with extreme care and avoiding potholes.
- Pay a lot of attention to possible obstacles (water, ice, debris, etc.) on the route of the stretcher. If you cannot set the path free from obstacles, choose an alternative route.
- The stretcher must be fully unfolded when driving.
- You must always drive with all four wheels in contact with the ground.
- A properly trained operator must always be in the control position.
- Always respect the maximum capacity of the device considering the total weight distributed according to the human anatomy and also taking into account the weight of the equipment and accessories. Do not circulate if the weight has not been distributed correctly.



In the event of any failure to conform to the above mentioned requirements you will be deemed fully responsible for all damages that might occur. In such cases, Promeba, S.L. will deny all responsibility for any malfunctions or injuries caused by the appliance itself; moreover product warranty will be considered void.

LOWERING THE STRETCHER

Before lowering the stretcher, reach the place where to make the following operations.

Lower the stretcher without body, as follows:

06 OPERATION

REV. 2025/01

1. Grab telescopic handles of the stretcher at the rear end (feet).
2. Lift the rear part (feet) of the stretcher, until the loading wheels touch the ground. (see photo aside)
3. Holding firmly the stretcher, push both command handles (see image aside) in order to close the legs.
4. Lower the stretcher, carrying its weight, until it touches the ground.

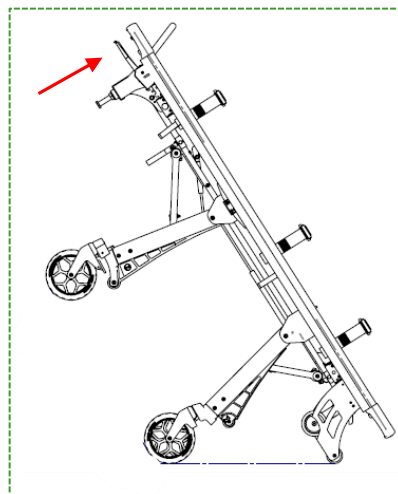

Before loading the patient, while the stretcher is on the ground, make sure the underground is stable and horizontal; unstable and non-horizontal surfaces may affect the static balance of the stretcher.

Brake the front wheels (optional) when the stretcher is on the ground and do not forget to unblock them before raising the stretcher.

LIFTING THE STRETCHER

Before lifting the stretcher fix the patient on the stretcher with the belts and make sure the underground is safe and stable.

The following procedure is recommended to lift the stretcher:

1. One operator must be positioned to each edge of the stretcher. The capacities of the various operators must be considered before determining his role in the process (consider how many operators to employ according to the weight to lift and according to the capacities of each operator).
2. Make sure to grab the stretcher firmly at both ends.
3. Using an adequate lifting technique, lift the stretcher until the legs, front and rear, are open and completely blocked.

LOADING THE STERTCHER ONTO THE AMBULANCE

Make sure the ambulance's doors are blocked correctly in open position, in order to avoid any interferences. Also make sure the loading platform is on the correct position.

During the charging operation:

1. Place the stretcher towards the rear door opening of the vehicle.
2. Push it onto the loading platform of the vehicle.
3. Make sure that both loading wheels are positioned on the loading platform (safety position). At the same moment, make sure the front wheels are between 4 and 6cm up from the floor and operate the red handle (1) to unlock the front legs.

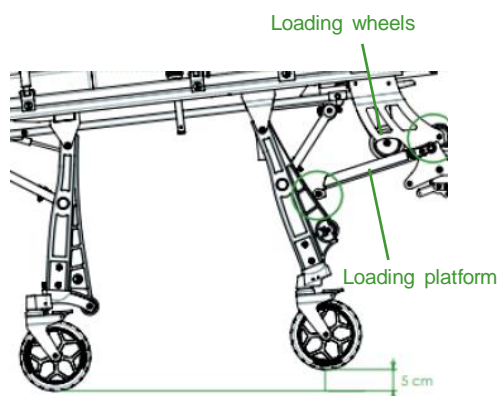

06 OPERATION

REV. 2025/01

4. Push the stretcher into the ambulance, keeping the red handle pushed so that the front legs fold up and close; avoid strong blows of the front legs against the load platform; the legs and related mechanisms could be damaged.

5. Insert the stretcher into the ambulance until the rear legs touch the platform, then lift the stretcher slightly and operate the green handle (2) to unlock the rear legs and complete the stretcher loading procedure.

* If you have a model with **Ergoload system** (see models with Ergoload in paragraph 02.3) do not operate the green handle at this step. Simply continue loading the stretcher onto the ambulance and the rear legs will automatically unlock.

6. Make sure the stretcher is securely attached to the vehicle locking system. It is recommended to use the original fixing systems Promeba, S.L. to ensure optimal stability in all directions. As long as other fixing systems are used, the safety and correct functionality of the device is not guaranteed.



UNLOADING THE STRETCHER FROM THE VEHICLE

During the download operation:

1. Unlock the stretcher from its fixation system.
2. Hold the stretcher by the rear telescopic handles and gently pull it out of the vehicle.
3. Hold the stretcher until the rear legs open and lock automatically.
4. **Before removing the loading wheels from the platform (safe position), make sure that the front and rear legs have been opened and locked correctly** and that the ground is stable and safe. If the legs are not completely opened and locked, the legs can fold accidentally causing risk of the patient fall and risk of injury of the operator or the patient. See point “*requirements of the vehicle*” in page 22 to regulate correctly the loading platform and make the unloading procedure out of risk.

Do not actuate any handle during unloading.



ATTENTION: When setting the loading height, the vehicle is considered to be on levelled ground. If this condition is not met when unloading the stretcher, its operation could vary slightly from what was expected. In this case, pay special attention that the front and rear legs are fully open and locked before removing the loading wheels from the platform.

INTERMEDIATE POSITIONS

Promeba stretcher has been designed to be able to adopt different heights, making easy the transfer of the body and optimizing the loading procedures. The stretcher is capable of adopting 4 intermediate positions, in addition to the maximum height (completely open) and the minimum height (completely closed).

The following procedure is recommended to reach the intermediate positions:

06 OPERATION

REV. 2025/01

1. Bring the stretcher to the place of operations and make sure the ground is stable and safe.
2. Two operators must be positioned to each edge of the stretcher
3. The operator positioned on the rear edge (feet) of the stretcher will lift it slightly and push the green handle (2) unlocking the rear legs.
4. Always supporting the stretcher load, lower it until the required position and let the handle go of.
5. The operator positioned on the front edge (head) of the stretcher will lift it slightly and push the red handle (1) unlocking the front legs.



6. Always supporting the stretcher load, lower it until the required position and let the handle go of.

The following procedure is recommended to return the stretcher to the standard position:

1. Two operators should be positioned at each edge of the stretcher.
2. Make sure the ground is safe and stable.
2. Hold the stretcher firmly at both ends.
3. Using proper lifting technique, raise the stretcher. The front legs will open and lock automatically.
4. The operator at the front edge should push the front legs with their foot until they are fully open and locked.

ADJUST PATIENT BOARD

Always inform the patient in case the patient board has to be adjusted.

Adjusting the backrest *(For all the models)*

Follow these indications:

1. Support the backrest with one hand (to avoid unexpected movements) and push the handle (figure aside) until the security mechanism is unblocked.
2. Always supporting the backrest with one hand, lower or lift the backrest until the required position and let the handle go (six positions, plus horizontal position, available).

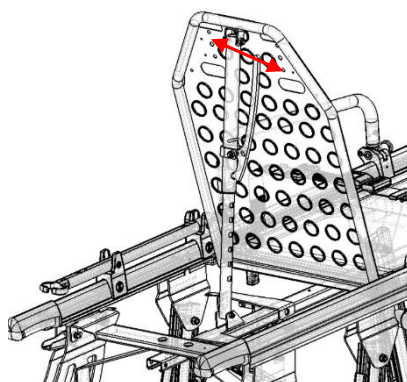

06 OPERATION

REV. 2025/01

Trendelenburg position *(For all the models)*

The Trendelenburg movement allows the lifting of the board in order to higher the legs of the patient (see Figure 4).

To put the board in Trendelenburg position:

1. Lift the board with one hand taking away the weight.
2. Select the required position by placing the rod onto one of the slots. There are three available positions, plus horizontal position.

To put the board horizontal again:

1. Lift slightly the board with one hand taking away the weight.
2. Release the rod from the slot and lower the board until the horizontal position is reached.



FIGURA 4

Fowler position *(Only for models PC9510-00000 and PC9520-00000)*

The Trendelenburg/Fowler movement allows the lifting of the patient board into different positions, in order to higher the legs of the patient (see figure 5).

To put the board in Fowler position:

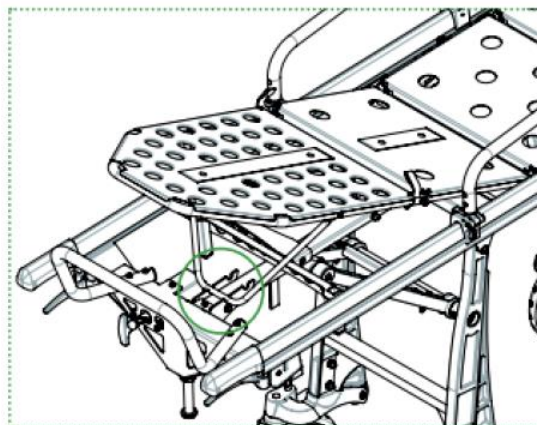
1. Support and lift the board with one hand taking away the weight.
2. Select the required position by placing the rod onto one of the slots (three positions, plus horizontal position, available).
3. Once on Trendelenburg position, pull the red straps placed on both sides of the board, at patient's knees height, to get the Fowler position.

To put the board horizontal again:

1. Pull the straps down to return to Trendelenburg position.
2. Lift slightly the board
3. Release the rod from the slot and lower the board until the horizontal position is reached.



FIGURA 5

06 OPERATION

REV. 2025/01

HANDRAILS

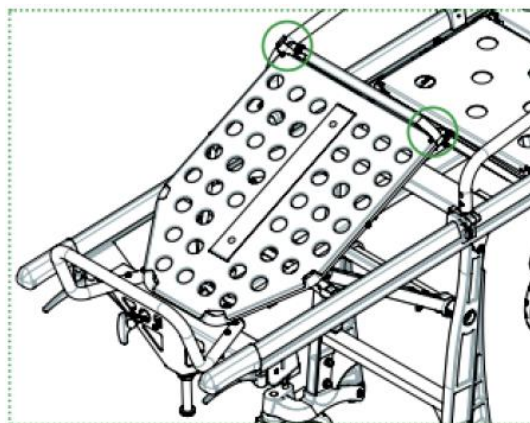
In order to avoid accidental functioning, the handrails are designed to be opened with two hands.

1. Use one hand to unlock the positioner (see figure 6).
2. With the other hand pull the handrail down until it rotates up to 180°.

To put the handrails back in upward position:

1. Rotate them until they are up and properly locked.



FIGURA 6

WHEELS

Brakes *(For all the models)*

The brakes can be inserted by pushing down the lever positioned on the upper part on all the wheels, (see figure 7). The brake system blocks the wheel, immobilizing the stretcher. To unblock the brakes, pull the lever on the wheels.

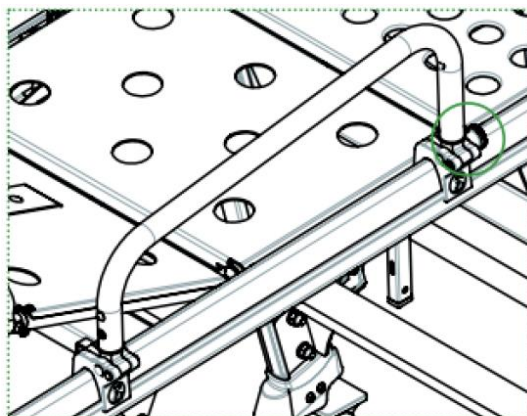

FIGURA 7

FIGURA 8

Locking the rear wheels *(models PC-901/7 y PC902/7)*

On models PC9017-00000 and PC9027-00000 the front wheels are always swiveling and the rear wheels can be locked. To lock them rotate 90° the red lever, positioned on the top of it (see figure 8), and it will shift down slightly locking the wheel.

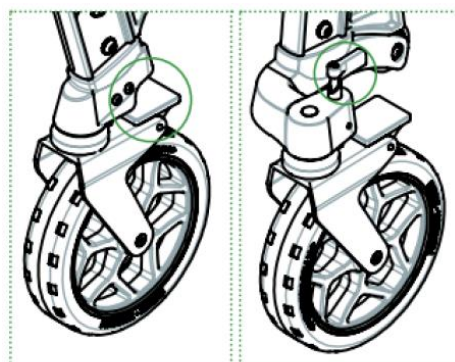
To unlock, rotate the lever it 90° on the opposite side.

Locking the rear wheels *(models PC-921/7 y PC922/7)*

On models PC9217-00000 and PC9227-00000 the front wheels are always locked, but the rear wheels can also be locked if the healthcare technician so wishes. The exact same procedure must be followed as for models PC9017-00000 and PC9027-00000 (see previous paragraphs).

06 OPERATION

REV. 2025/01

QUICK LOCK SYSTEM (models PC-911/7, PC912/7, PC-913/7, PC-951 Y PC-952)

El Sistema Quick Lock system permite bloquear y desbloquear las ruedas delanteras de la camilla desde la posición de mando, es decir, desde detrás.

Cuando la maneta que se encuentra en la parte de detrás de la camilla, justo debajo de la litera está en posición vertical, las ruedas estarán desbloqueadas, con el pin que bloquea, situado en la horquilla de la rueda, tirado hacia arriba. Para bloquear las ruedas, girar la maneta y ponerla en posición horizontal. Las ruedas girarán hasta que el pin bloqueador entre en el agujero de la horquilla.



Para desbloquear las ruedas, realice el movimiento contrario, dejando la maneta en posición vertical.



- The Quick Lock System handle is placed in the rear part of the stretcher, below the footrest.
- It has 2 positions, wheels blocked, wheels unblocked.

- The Quick Lock System allows blocking and unblocking the front wheels.

06.4. Troubleshooting

Problem	Cause	Remedy
Pushing the stretcher against the loading platform, the legs do not fold away	The handle has not been actioned correctly or the metal cable under the stretcher does not transmit the commands	Fully operate the handle. If the problem is not solved, try to activate the handle and see if cable is transmitting the movement to the pin. If not, contact the technical service
During patient transport it is difficult to move the stretcher	There may be an obstruction in the wheels: the brakes are still blocked or there is some external element blocking them.	Unlock the brakes or check that there is nothing blocking the wheels. Check the condition of the wheels.
Structural damage	Improper use or operators not adequately trained	Put the stretcher out of service immediately and contact the technical service

07.1. Cleaning

It is essential to keep the equipment clean to ensure proper use and durability of the set. Thorough cleaning should be carried out periodically, especially in areas exposed to dirt that can accumulate dirt such as corners or holes.

Do not use high pressure cleaning systems or bleach to disinfect the product, they can damage it. Instead, use a hydroalcoholic-based disinfectant, wash it with water and let it dry naturally, do not use direct heat sources to dry.

Non-compliance with cleaning operations can lead to the risk of cross infections due to the presence of secretions and/or residues. During all control and disinfection operations, the operator must wear appropriate personal protective equipment, such as gloves, glasses, etc.

When the cleaning procedure includes a disinfectant product, carefully follow the instructions of the manufacturer of the product used regarding the method of application and contact time. Make sure that you have taken all the necessary precautions to ensure that there are no risks of cross-infection or contamination of patients and operators.

MAKE SURE TO KEEP AREAS FROM FIGURES ON THE RIGHT FREE OF WATER AND HUMIDITY. TAKE SPECIAL CARE NOT TO GET THEM WET WHILE WASHING THE SET.

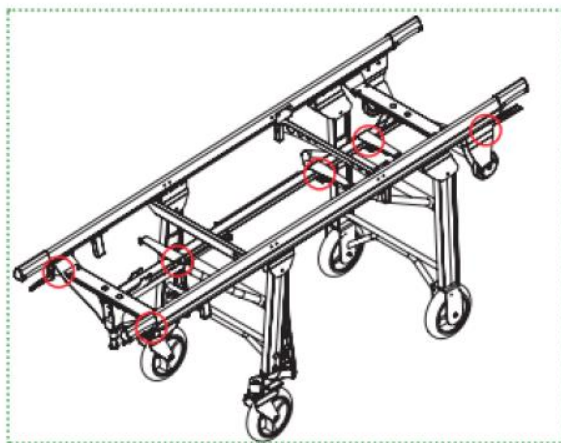

Failure to carry out the correct cleaning routine could increase the risk of cross infection, due to presence of body fluids and/or residuals. The operator must always wear adequate personal protection such as gloves and mask, etc. during all checking and cleaning procedures.

07.2. Lubricating

In general, all moving parts must be greased. Our products leave the factory completely greased and lubricated, however, it is possible that over time and use of the product the elements become degreased, either due to loss of lubrication or due to dirt.

Periodically clean and oil affected areas according to manufacturer's specifications. Check for loose, missing or worn parts.

Never lubricate the belts. Lubrication can cause the belts to perform unpredictably, which can cause injury to the patient and/or operators.

07.3. Wear areas

Periodic inspection of the different components of the system for signs of wear is a preventative measure that can reduce breakdowns. Check possible lubricant leakages,

07 GENERAL MAINTENANCE

REV. 2025/01

grooves or bearing in poor condition. Check also, due to intensive usage, the moving parts such the handles, the wheels and the folding system of the legs.

In the event that a worn component needs to be changed, you should contact our sales department for more information on ordering spare parts and their installation.

The repair or replacement of product components must necessarily be carried out by qualified personnel, that is, who have received training from the Manufacturer, Promeba S.L. and original spare parts should always be used.

Promeba S.L. declines any responsibility for any damage, direct or indirect, resulting from improper use of spare parts and/or any repair intervention carried out by unauthorized persons.

07.4. Maintenance program

Although the frequency of the controls is determined by factors such as legal requirements, the type of use, the frequency of use, the environmental conditions during use and storage, it is placed a recommendation on the maintenance that the equipment must have for correct operation throughout its useful life.

All maintenance and revision activities must be recorded and documented with the corresponding technical intervention reports, and the documentation must be kept for at least 10 years from the end of the product's useful life and must be made available to the competent Authorities and/or from the Manufacturer, when requested.

Maintenance review	Every use	When necessary	Every month	Every year	Every 4 years
Disinfect	X				
Clean		X			
Inspect	X	X			
Grease necessary components		X		X	
Change springs				X	
Change wheels					X

For both the disinfection and cleaning procedures, point 7.1 of this manual must be followed.

During the inspection procedure, which must be done after each use, the following tasks must be carried out:

- Check that all components are present.
- Check the integrity of the device, that is, that there are no breaks, cracks, holes or cuts.
- Check the wear of the product following section 7.3 of this user guide.
- Check that the moving parts slide correctly.
- Check that the accessories provided are present, intact and that they function correctly.

For some conditions of use, due to vibrations or impacts, certain elements may lose their tightening torque or fixing properties. Periodically check for loose items, especially moving parts. Inspect any mechanical connections. Always observe and adhere to the recommended tightening torques.

08 SPARE PARTS

REV. 2025/01

To request a spare part, indicate:

- Number and description of the set in which the necessary part is found (see table)
- Point out the piece in the drawing, or the area where it is located.

Following these instructions, our sales department will provide you with a detailed drawing of the assembly so that you can specify the reference of the required spare part.

Nº	COMPONENTS DESCRIPTION	Nº	COMPONENTS DESCRIPTION
1a	TRAY (TEXTILE PART)	15	FRONT WHEELS CASING SUPPORT
1b	TRAY (ALUMINIUM BACK)	16	FRONT SUPPORT
2	BELTS	17	MAIN DAMPER
3	MATRESS	18	REAR LEGS SUPPORT
4	BACKREST HANDLE	19	FOOTREST
5	LOADING WHEELS	20	STRETCHER GUIDE
6	LOADING WHEELS SUPPORT	21	GREEN HANDLE
7	INTERMEDIATE POSITION HANDLE	22	RED HANDLE
8	AMORTIGUADOR PATA TRASERA	23	TELESCOPIC HANDLES
9	REAR LEGS DAMPER	24	MAIN PROFILES ASSEMBLY
10	LEFT REAR WHEEL CASING	25	QUICK LOCK SYSTEM HANDLE
11	MAIN WHEEL	26	IV POLE
12	RIGHT REAR WHEEL CASING	27	FOLDABLE HANDRAILS
13	FRONT LEGS	28	10G PIN
14	PLASTIC SLIDER		

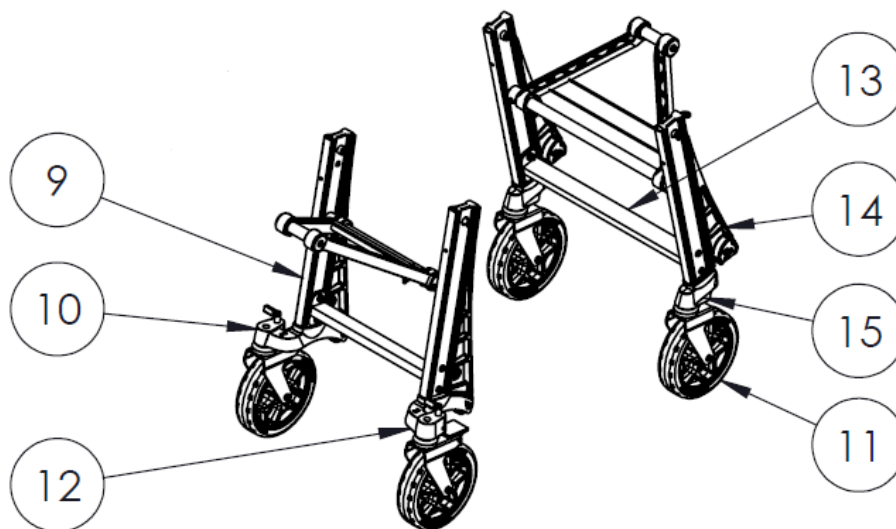

08 SPARE PARTS

REV. 2025/01

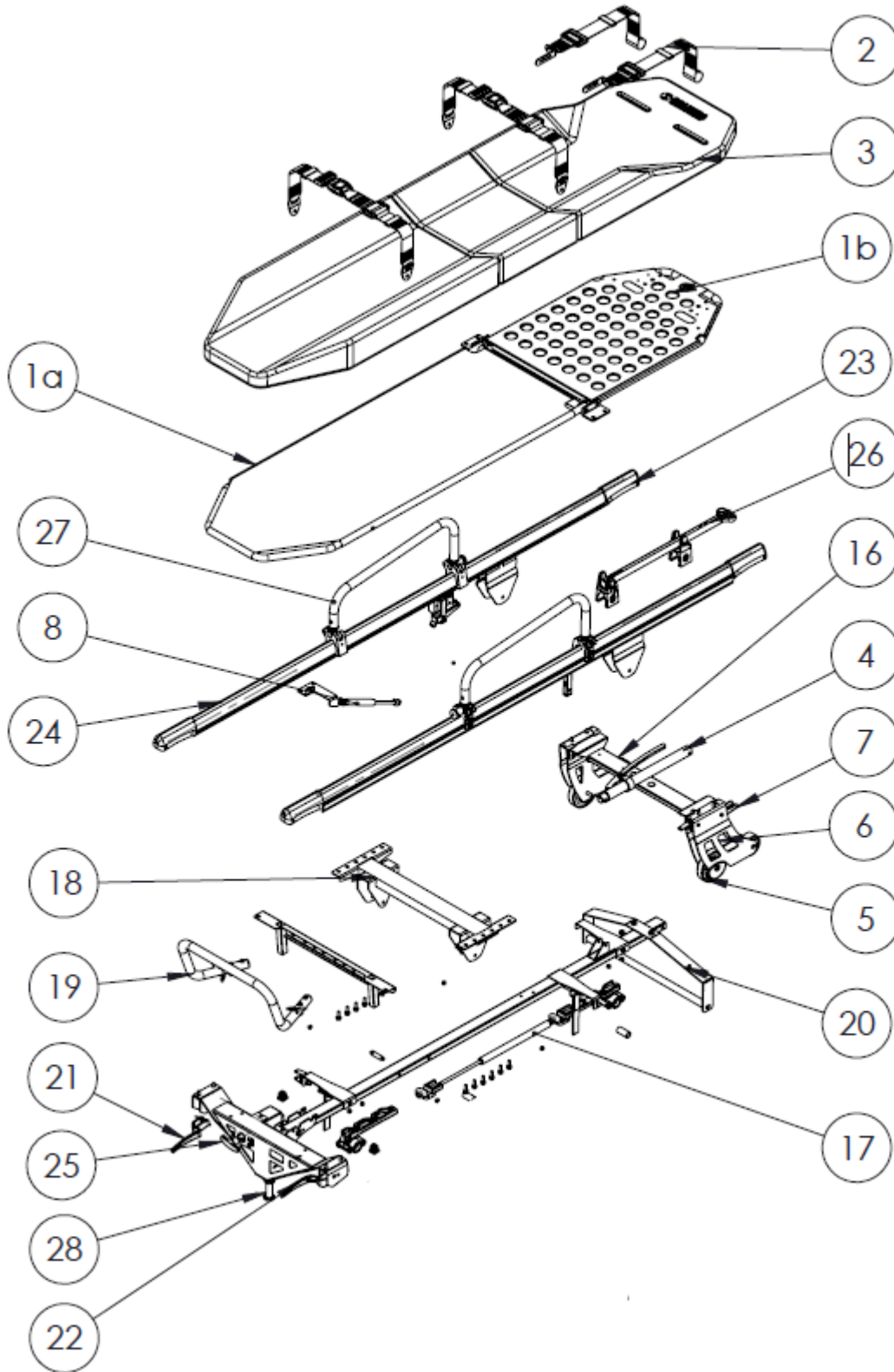

11 LEGAL NOTICES

REV. 2025/01

- This document may contain technical inaccuracies or typographical mistakes.
- Changes are periodically added to the information herein; these changes will be incorporated in new editions of the publication.
- Promeba, S.L. reserves the right to make any modification or improvement in the products described in this publication if it is appropriate.
- Promeba, S.L. may have patents or patent applications which address themes described in this document. The possession of this document does not entitle no license to these patents. The information contained in this document does not affect or change the specifications or product specifications or warranties of Promeba, S.L.
- No part of this document shall operate as express or implied license or compensation under the intellectual property rights of Promeba, S.L. or third party.
- All the information contained in this document has been obtained in specific environments and it is presented as an illustration. The results obtained in other operating environments may vary.
- Promeba, S.L. can use or distribute the information that the customer provides in whatever way they see fit, without incurring any obligation with the client.

12 PRODUCT WARRANTY

REV. 2025/01

Promeba, S.L. guarantees that its products have satisfactorily passed all established quality controls, both functional and material. The duration of the guarantee is 2 years from the date of purchase of the product.

This guarantee will be valid only when it is presented with the original invoice or proof of purchase (indicating the date of purchase, model and the name of the distributor) together with the defective product during the period covered by the guarantee. Promeba, S.L. reserves the right not to offer the free warranty service if the indicated documents are not presented or if the information they contain is incomplete or illegible.

1. This warranty will not apply if the model name or serial number of the product has been altered, erased, disappeared or becomes illegible.

2. This guarantee does not cover transportation costs or risks derived from the transportation of your product to and from Promeba, S.L.

3. This warranty does not cover any of the following:

- a) Periodic maintenance and repair or replacement of parts derived from normal wear and tear.
- b) Expendable material (components that are expected to need periodic replacement during the life of the product, such as belts, straps, etc.).
- c) Damages or defects derived from the improper use, operation or treatment of the product and not due to normal use of the product.
- d) Damages derived from:
 - i. Misuse, including:
 - Treatment that results in damages or physical, superficial or appearance changes of the product.
 - Installation, use or storage of the product in a way that does not

respect the instructions described by Promeba, S.L.

- Maintenance of the product in a way that does not respect the instructions of Promeba, S.L. for proper maintenance.

- Installation or use of the product in a way that does not respect the technical or safety regulations of the country where it is used or installed.

ii. Use of components not provided with the product or incorrect installation of accessory parts not previously tested.

iii. States or defects of the system in which the product is used or incorporated with the exception of other products Promeba, S.L. designed for use with the product.

iv. Use of the product with accessories, peripheral units and other products of a type, condition or standards not established by Promeba, S.L.

v. The manufacturer or distributor will be solely responsible for deciding whether to send the parts for repair, or to replace the product in its entirety. In no case will operators be sent to repair or replacement of the product.

Except in the cases mentioned above, Promeba, S.L. will make no warranties in relation to product, performance, accuracy, reliability, or fitness for logic purpose of the equipment or other type. If this exception is not legal or contemplated by current law, Promeba, S.L. will limit or exclude your warranties only to the extent permitted by applicable law.

The only obligation on the part of Promeba, S.L. in connection with this warranty is to repair or replace parts subject to the terms and conditions of this warranty.

Promeba, S.L. is not responsible for loss or damage to products, this warranty or others, including economic loss or non-assessable

12 PRODUCT WARRANTY

REV. 2025/01

damage; the price paid for the product; loss of profits, income, information, usufruct or use of the product or associated products or indirect, accidental or critical loss or damage.

This clause refers to whether the loss or damage is due to deterioration or inoperability of the associated product due to defects or unavailability of Promeba, S.L., which has caused downtime, loss of user time or business interruption.

In cases where the law prohibits or limits these liability exclusions, Promeba, S.L. will exclude or limit his liability only to the extent permitted by applicable law.

For example, there are countries that prohibit the exclusion or limitation of damages caused by negligence, reckless negligence, willful misconduct, fraud and similar actions. The responsibility of Promeba, S.L. In this guarantee will not exceed, in any case, the price paid for the product, but if the current law allows only limitations of greater responsibilities, these will apply.



Todos los derechos reservados. Reservado el derecho ha modificaciones sin previo aviso.
Promeba, S.L. no se considera responsable de los daños causados por la falta o la inexactitud de la información aquí mencionada.

*All rights reserved. Variations can be done whitout notice.
Promeba, S.L. is to be considered not responsible for damages caused by the lack or the wrongness of the information here mentioned.*

SCAN QR CODE



Productos Metálicos del Bages, SL

Ctra C-16 Km 59.5 · 08650 Sallent (Barcelona) · SPAIN

T. 93 837 12 00

promeba@promeba.com · www.promeba.com